

Schüco Living

Bestellkatalog Kunststoff-Systeme
Order Manual PVC-U Systems



Hinweise zur Nutzung des Katalogs

Diese Broschüre ist eine Bestell- und Verkaufsunterlage für das Twinsystem Schüco LivIng.

Sämtliche Bestellinformationen sind enthalten.

Fertigungsinformationen werden in den entsprechenden Fertigungsunterlagen zur Verfügung gestellt.

PVC-, Stahl- und Aluminiumprofile werden in Längen von 6 m geliefert. Alle Ausnahmen sind auf den jeweiligen Seiten des Kataloges gekennzeichnet.

Alle Artikelnummern sind 8-stellig.

Bei PVC-Profilen geben die letzten drei Ziffern die Farbausführung an, z.B. 1 8596 160.

Üblicherweise werden in unseren Katalogen nur die ersten fünf Stellen der Artikelnummer eines Profils angegeben.

Den entsprechenden Farbcode und die Verfügbarkeit können der Folierungsübersicht entnommen werden.

Es ist zu beachten, dass alle angegebenen Farben Schüco-Farben entsprechen.

weiß : ähnlich RAL 9016

schwarz : ähnlich RAL 9005

cremeweiß : ähnlich RAL 9001

braun : ähnlich RAL 8014

karamell : ähnlich RAL 8001

grau : ähnlich RAL 7035

dunkelgrau : ähnlich RAL 7015

Aluminiumprofile liefern wir in roher, eloxierter oder farbbeschichteter Ausführung.

Bei der Bestellung ist die gewünschte Oberflächenveredelung gemäß RAL-Farbfächer anzugeben.

Instructions for using the manual

This brochure constitutes order and sales documentation for the Schüco LivIng Twin System.

All of the order information is included.

Fabrication information is provided in the corresponding fabrication documentation.

PVC, steel and aluminium profiles are supplied in 6 m lengths. Any exceptions to this are indicated on the relevant pages of the manual.

All article numbers have 8 digits.

For PVC profiles, the last 3 digits indicate the colour design, e.g. 1 8596 160.

As a rule, only the first 5 digits of a profile article number are indicated in our manuals.

The corresponding colour code and the availability can be found in the foiling overview.

It must be ensured that all specified colours match Schüco colours.

White: similar to RAL 9016

Black: similar to RAL 9005

Cream white: similar to RAL 9001

Brown: similar to RAL 8014

Caramel: similar to RAL 8001

Grey: similar to RAL 7035

Dark grey: similar to RAL 7015

Aluminium profiles are supplied either in mill finish, anodised or colour-coated.

When ordering, the required surface finish must be indicated as per the RAL colour charts.



Iconübersicht
Icon overview

Iconübersicht

Icon overview



siehe Seite
See page



Blendrahmen
Outer frame



Flügelrahmen
Vent frame



T-Profil
T-profiles



Stulpprofil
Double-vent profiles



Flügelrahmen, nach außen öffnend
Vent frame, outward-opening



Glasleisten
Glazing beads



Statische Werte in cm4
Structural values in cm4



Profilwandstärke
Profile wall thickness



Lagerlänge
Stock length



Farbe
Colour



Verpackungseinheit
Packing unit

Stk. = Stück ■ Quantity

m = Meter ■ Metre(s)

m* = Meter auf Mehrwegspule ■ Metres on reusable spool

P. = Paar ■ Pair(s)



Infos, Tipps und Ratschläge
Information, tips and advice



Hinweis Achtung
Important note



Glasdicke
Glass thickness



Abmaße, Abmessungen
Size, dimensions



Türschwelle durchlaufend
Door threshold, continuous



Graue Dichtung
Grey gasket



Schwarze Dichtung
Black gasket



Lagerprofil entsprechend Foliensortiment
Stock profile in accordance with range of foils



Grundkörperfarbe weiß
Colour of base material White



Grundkörperfarbe dunkelgrau
Colour of base material Dark grey



Grundkörperfarbe karamell
Colour of base material Caramel

Inhalt
Inhalt

03	Systemeigenschaften System features
21	Profile Profiles
79	Folierung Foiling
91	Verglasung Glazing
113	Schnittdarstellungen 1:1 Section details 1:1



Systemeigenschaften
System features

Systemeigenschaften
System features

03

- 04 Produktvorteile
Product benefits
- 08 Wärmedämmung Schüco LivIng 82 AS
Schüco LivIng 82 AS thermal insulation
- 09 Wärmedämmung Schüco LivIng 82 MD
Schüco LivIng 82 MD thermal insulation
- 10 Systemschnitt 1:1
System section detail 1:1
- 12 Elementtypenübersicht
Overview of unit types
- 14 Maximale Flügelgrößen
Maximum vent sizes
- 15 Eckfestigkeit
Corner stability

Produktvorteile Product benefits

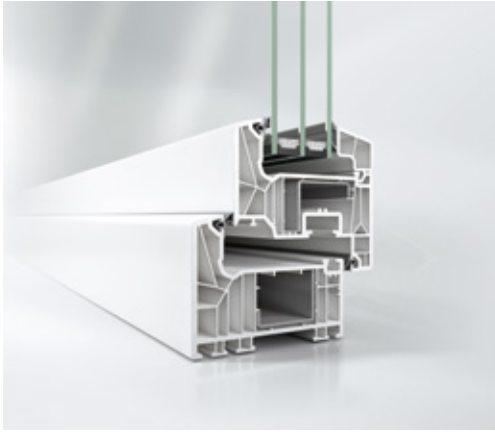

Schüco LivIng 82 AS

Das Kunststoff-System Schüco LivIng ist ein innovatives 7-Kammer-System, das als Twin-System sowohl mit Anschlag- als auch mit Mitteldichtung gefertigt werden kann.

In beiden Dichtungsvarianten werden umlaufend erstmals mitschweißende EPDM-Funktionsdichtungen eingesetzt.

In Verbindung mit der Mitteldichtung erreicht das System Passivhaustauglichkeit entsprechend ift-Richtlinie WA-15/2.

Auch in Verbindung mit der Anschlagdichtung verfügt das System über hervorragende Wärmedämmeigenschaften bei gleichzeitig schmalen Ansichtsbreiten.

The Schüco LivIng PVC-U system is an innovative 7-chamber system that can be made as a twin system with both a rebate gasket and a centre gasket. In both gasket variants, continuous weld-on EPDM functional gaskets are used for the first time.

In conjunction with the centre gasket, the system achieves passive house standard in accordance with ift guideline WA-15/2.

Also in conjunction with the rebate gasket, the system combines excellent thermal insulation properties and narrow face widths.

Technische Informationen Technical information	Classic AS	Classic MD
Abmaße Dimensions		
Bautiefe Blendrahmen Basic depth of outer frame	82 mm	82 mm
Bautiefe Flügelrahmen Basic depth of vent frame	82 mm	82 mm
Mögliche Verglasungsstärke Possible glazing thickness	24 mm – 52 mm	24 mm – 52 mm
Prüfungen und Normen Tests and standards		
Wärmedämmung nach DIN EN 12412-2** Thermal insulation in accordance with DIN EN 12412-2**	$U_t = 1,0 \text{ W}/(\text{m}^2\text{K})$	$U_t = 0,96 \text{ W}/(\text{m}^2\text{K})$
Schalldämmung nach DIN EN ISO 140-3 (maximal)* Sound reduction in accordance with DIN EN ISO 140-3 (maximum)*	$R_{w,p} = 47 \text{ dB}$	$R_{w,p} = 47 \text{ dB}$
Einbruchhemmung nach DIN EN 1627 Burglar resistance in accordance with DIN EN 1627	RC 2	RC 2
Luftdurchlässigkeit nach DIN EN 12207 (Klasse) Air permeability in accordance with DIN EN 12207 (Class)	4	4
Schlagregendichtheit nach DIN EN 12208 (Klasse) Watertightness in accordance with DIN EN 12208 (Class)	9A	9A
Widerstandsfähigkeit bei Windlast DIN EN 12210 (Klasse)** Resistance to wind load in accordance with DIN EN 12210 (Class)**	C5/B5	C5/B5
Mechanische Beanspruchung nach DIN EN 13115 (Klasse) Mechanical loading in accordance with DIN EN 13115 (Class)	4	4
Dauerfunktion nach DIN EN 12400 (Klasse) Resistance to repeated opening and closing in accordance with DIN EN 12400 (Class)	2	2
Bedienkräfte nach DIN EN 13115 (Klasse) Operating forces in accordance with DIN EN 13115 (Class)	1	1
Tragfähigkeit von Sicherheitsvorrichtungen Load-bearing capacity of safety devices	Anforderung erfüllt Requirement met	Anforderung erfüllt Requirement met

* Profil- und verglasungsabhängig
* Dependent on profile and glazing

** Profilabhängig
** Dependent on profile



Schüco LivIng 82 MD foliert auf dunkelgrauem Grundkörper
Schüco LivIng 82 MD foiled on dark grey basic structure



 Produktvorteile	Product benefits
<ul style="list-style-type: none"> ▪ Kombisystem mit gleichen Flügelprofilen für Mittel- und Anschlagdichtung ▪ ift Passivhaustauglich mit Mitteldichtung ▪ Einheitliches Dichtungskonzept in beiden Systemen ▪ Eine, auch im kritischen Eckbereich weiche, umlaufend geschlossene Dichtungsebene gewährt die maximale Funktionssicherheit ▪ Identische Stulpprofile für Mittel- und Anschlagdichtung ▪ Korrespondierender Falz bei Blendrahmen-, Flügelrahmen- und T-Profilen zur Teilereduktion z.B. bei T-Verbindern ▪ Hohe Funktionssicherheit durch 6 mm Flügelüberschlag außen und 8 mm innen ▪ Hohe Toleranzaufnahme durch 5 mm Dichtungsspaltmaß zwischen Blend- und Flügelrahmen ▪ Spezielles Flügelrahmenprofil für den Einsatz der Klebetechnik ▪ Optimierte Falzgrundgeometrie ermöglicht den optionalen Einsatz der additiven Klebetechnik ▪ Glasleistenhöhe von 25 mm für erhöhten Glaseinstand ▪ Werkseitig maschinell eingerollte, hochwertige EPDM-Funktionsdichtungen, schweißbar ▪ Wanddicken nach RAL-GZ/716 und DIN EN 12608 ▪ Vollständig recyclebar 	<ul style="list-style-type: none"> ▪ Combined system with the same vent profiles for centre and rebate gaskets ▪ ift passive house compatible with centre gasket ▪ Uniform gasket concept in both systems ▪ A continuous, closed drainage level that is even soft in the critical corner area ensures maximum functional performance ▪ Identical double-vent profiles for centre and rebate gaskets ▪ Corresponding rebate for outer frame, vent frame and T-profiles for reduction in components e.g. for T-cleats ▪ High level of functional reliability with 6 mm vent overlap outside and 8 mm inside ▪ 5 mm gasket clearance takes up tolerances between outer and vent frames ▪ Special vent frame profile for the use of adhesive technology ▪ Optimised rebate base geometry allows additive adhesive technology to be used ▪ Glazing bead height of 25 mm for increased glass edge cover ▪ High-quality EPDM functional gaskets machine-rolled in the factory, can be welded ▪ Wall thicknesses in accordance with RAL-GZ/716 and DIN EN 12608 ▪ Fully recyclable

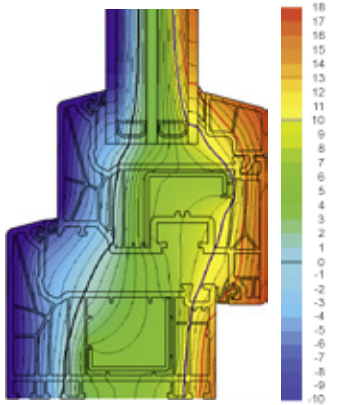

Isotherme Schüco LivIng 82 AS
Isothermal flow in Schüco LivIng 82 AS

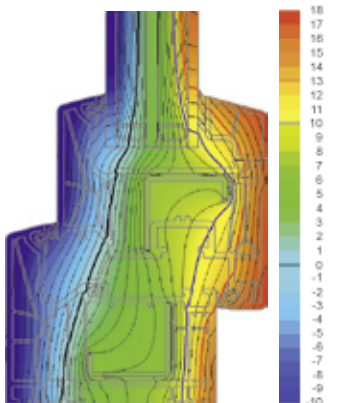

Isotherme Schüco LivIng 82 MD
Isothermal flow in Schüco LivIng 82 MD

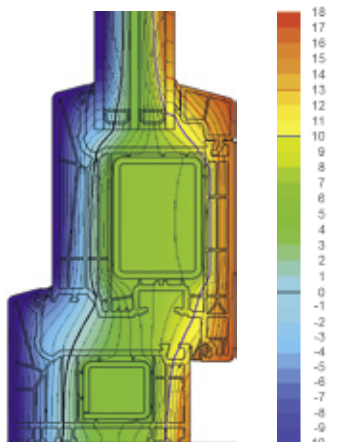

Isotherme Schüco LivIng 82 AS
mit Haustürflügel
Isothermal flow in
Schüco LivIng 82 AS with
entrance door leaf

Produktvorteile	Product benefits
<p>Energie</p> <ul style="list-style-type: none"> 7-Kammer-Profilkonstruktionen mit optimierter Kammergeometrie und einer Rahmenbautiefe von 82 mm für höchste thermische Isolation U_f-Werte von bis zu 0,96 W/(m²K) möglich Parallel angeordnete Profilkammern sorgen für einen idealen Verlauf der Isothermen Flügelüberschlag von 8 mm minimiert Wärmeverluste Glaseinstand von 20 mm und optimierte Glasfalzausprägung für geringen Wärmeverlust im Bereich des Glasverbunds Verglasung mit einer Glasstärke von 24 mm bis 52 mm möglich 	<p>Energy</p> <ul style="list-style-type: none"> 7-chamber profile constructions with optimised chamber geometry and a basic frame depth of 82 mm for maximum thermal insulation U_f values up to 0.96 W/(m²K) possible Profile chambers arranged in parallel ensure ideal isothermal flow Vent overlap of 8 mm minimises heat loss Glass edge cover of 20 mm and optimised glazing rebate shape for minimal heat loss in the glass seal area Glazing with a glass thickness of 24 to 52 mm possible
<p>Komfort</p> <ul style="list-style-type: none"> Schmale Ansichtsbreite von 120 mm (Standard Profilkombination) unterstreicht die schlanke Optik des Fensters Hervorragende Schallschutzwerte Bündige Glasleisteninnenkanten ermöglichen leichte und problemlose Reinigung der Fenster Dichtungsspalt von 5 mm gewährleistet ein weiches Schließen der Fenster 	<p>Comfort</p> <ul style="list-style-type: none"> Narrow face width of 120 mm (standard profile combination) highlights the slimline look of the window Excellent sound reduction values Flush glazing bead inner edges make the windows easy to clean Gasket clearance of 5 mm ensures the windows close smoothly
<p>Design</p> <ul style="list-style-type: none"> Flügelgeometrie in flächenversetzter Flügeloptik (Classic) Verschiedene Glasleistenkonturen als optisches Gestaltungsmittel Identische Glasleisten für Flügel- und Blendrahmenfestverglasung Weißer Profile werden standardmäßig mit farblich modernen silbergrauen, folierte Profile mit schwarzen Dichtungen geliefert Verglasungsdichtung mit Fahne als Sichtabdeckung beim Glaseinstand Die bündig sitzenden Dichtungen passen sich optimal in die Fensteroptik ein Farbliche Gestaltung der Profile durch eine große Auswahl an Unifarben und Holzdekoren möglich Schüco AutomotiveFinish ist zudem eine brillante Gestaltungsmöglichkeit mit exklusiven Metallicfarben 	<p>Design</p> <ul style="list-style-type: none"> Vent geometry with rebated appearance (Classic) Various glazing bead contours as a design feature Identical glazing beads for vent frame and outer frame fixed glazing White profiles are supplied with modern, silver-grey gaskets, foiled profiles with black gaskets as standard Glazing gasket with fin to hide the glass edge cover The flush fitting gaskets blend in perfectly with the appearance of the window Profiles can be coloured with a large selection of single colour and woodgrain decorative foils Schüco AutomotiveFinish is also a brilliant design option with exclusive metallic colours

	Produktvorteile	Product benefits
	<p data-bbox="544 506 639 528">Sicherheit</p> <ul data-bbox="544 551 991 987" style="list-style-type: none"> ▪ Ecklagerverschraubung im Flügel erfolgt durch spezielle Schraubkanäle ▪ Beschlagachse von 13 mm ermöglicht den Einsatz von einbruchhemmenden Beschlagteilen ▪ Erhöhte Bautiefe für mehr Sicherheit und Einbruchschutz ▪ Bei erhöhten Sicherheitsanforderungen ist der Einsatz von Sicherheitsriegelstücken mit Verschraubung in der Stahlarmierung möglich ▪ Bei dem System mit Mitteldichtung werden alle Beschlagteile durch die Mitteldichtung vor Korrosion und Verschmutzung geschützt ▪ Zur optimalen Befestigung der T-Verbinder sind vier Schraubkanäle vorhanden 	<p data-bbox="1038 506 1102 528">Security</p> <ul data-bbox="1038 551 1469 987" style="list-style-type: none"> ▪ Special screw ports for fixing the corner pivot in the vent ▪ The fittings axis of 13 mm allows the use of burglar-resistant fittings components ▪ Increased basic depth for added security and burglar resistance ▪ Security locking keeps with a screw fixing in the steel reinforcement can be used for increased security requirements ▪ For the system with the centre gasket, all fittings components are protected from corrosion and against dirt by the centre gasket ▪ There are four screw ports for optimum fixing of the T-cleats
	Verarbeitungsvorteile	Fabrication benefits
	<p data-bbox="544 1070 719 1093">Systemverarbeitung</p> <ul data-bbox="544 1115 991 1843" style="list-style-type: none"> ▪ Identische Systemmaße z.B. Glasabzugsmaß bei Verarbeitung mit Anschlag- und Mitteldichtung ▪ Gleiche Verstärkungsprofile für Blend- und Flügelrahmen ▪ Eine einheitliche Falzhöhe von 3 mm ermöglicht identische Fräsbilder für die T-Verbindung ▪ Sichtbare oder verdeckte Blendrahmenentwässerung, je nach Bausituation auf mehreren Ebenen möglich ▪ Durch 5 mm Dichtungsspalt zwischen Blend- und Flügelrahmen kann auf das Ausklinken der Flügelanschlagdichtung im Scherenlagerbereich verzichtet werden ▪ Klotzbrücke mit selbstlehrender Klemmung für eine sichere und einfache Montage ▪ Mitteldichtungsübergreifender T-Verbinder erspart das Ausklinken der Mitteldichtung ▪ Klipshaken an den Stulpprofilen als Positionierungshilfe zur einfachen Montage und mittigen Verschraubung ▪ Belüftung der farbigen Stulpprofile erfolgt über die Endkappen 	<p data-bbox="1038 1070 1198 1093">System processing</p> <ul data-bbox="1038 1115 1469 1821" style="list-style-type: none"> ▪ Identical system dimensions, e.g. glass deduction, when fabricating with rebate gasket and centre gasket ▪ Identical reinforcing profiles for outer and vent frames ▪ Uniform rebate height of 3 mm allows identical machining patterns for the T-joint ▪ Visible or concealed outer frame drainage possible on several levels to suit requirements ▪ Due to the 5 mm gasket clearance between the outer and vent frames, the vent rebate gasket does not need to be notched in the turn/tilt mechanism pivot area ▪ Glazing bridge with self-locating clamp for secure and easy installation ▪ T-cleat can be used with all centre gaskets, which removes the need for notching the centre gasket ▪ Cliphook on the double-vent profiles as a positioning aid for simple installation and central screw connection ▪ Coloured double-vent profiles are ventilated via the end caps

Wärmedämmung Schüco LivIng 82 AS

Schüco LivIng 82 AS thermal insulation

U_w -Wert Berechnung nach DIN 10077 bezogen auf ein Fenstermaß von 1230 x 1480 mm, Ansichtsbreite 120 mm

U_w value calculation in accordance with DIN 10077 Based on window dimensions of 1230 x 1480 mm with a frame face width of 120 mm

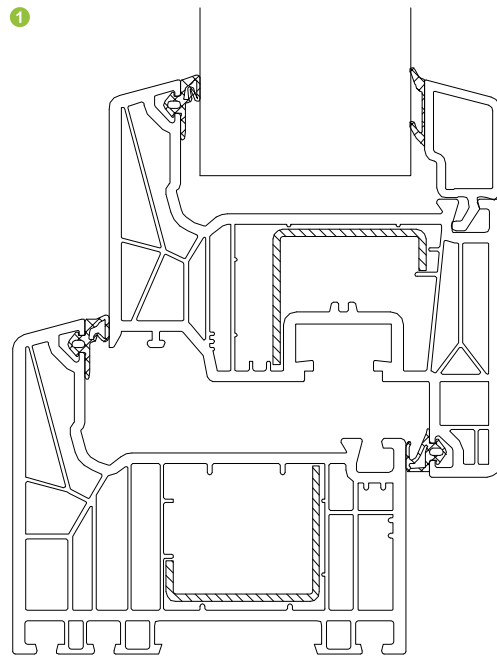

Schüco LivIng 82 AS mit Stahl 20271500 und 20271500
Prüfbericht 15-002325-PR 26
Schüco LivIng 82 AS with steel 20271500 and 20271500
Test report 15-002325-PR26

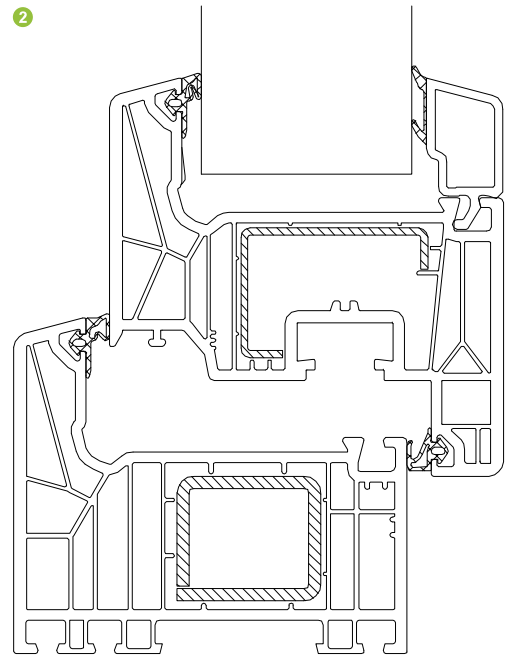

Schüco LivIng 82 AS mit Stahl 20271900 und 20272500
Siehe Prüfbericht System U-Wert
Schüco LivIng 82 AS with steel 20271900 and 20272500
See U value test report for system

Randverbund Edge seal	Psi (W/mK)	U_r (W/m ² K)	
		①	②
		1,0	1,1
$U_g = 0,7$ (W/m²K)		U_w (W/m²K)	
Alu Aluminium	0,078	0,99	1,02
Edelstahl Stainless steel	0,050	0,92	0,95
Thermix	0,039	0,89	0,93
Swisspacer Advance	0,037	0,89	0,92
Swisspacer Ultimate*	0,024	0,86	0,89
$U_g = 0,5$ (W/m²K)			
Alu Aluminium	0,078	0,85	0,89
Edelstahl Stainless steel	0,050	0,79	0,82
Thermix	0,039	0,76	0,79
Swisspacer Advance	0,037	0,75	0,79
Swisspacer Ultimate*	0,024	0,72	0,75
$U_g = 0,4$ (W/m²K)			
Alu Aluminium	0,078	0,79	0,82
Edelstahl Stainless steel	0,050	0,72	0,75
Thermix	0,039	0,69	0,72
Swisspacer Advance	0,037	0,69	0,72
Swisspacer Ultimate*	0,024	0,65	0,69

*Psi-Wert für den Swisspacer Ultimate in Kombination mit dem System Schüco LivIng gemäß ift-Prüfzeugnis 15-000619-PR04

*Psi value for the Swisspacer Ultimate in combination with the Schüco LivIng system in accordance with ift test certificate 15-000619-PR04

Wärmedämmung Schüco LivIng 82 MD

Schüco LivIng 82 MD thermal insulation

U_w -Wert Berechnung nach DIN 10077 bezogen auf ein Fenstermaß von 1230 x 1480 mm, Ansichtsbreite 120 mm

U_w value calculation in accordance with DIN 10077 Based on window dimensions of 1230 x 1480 mm with a frame face width of 120 mm

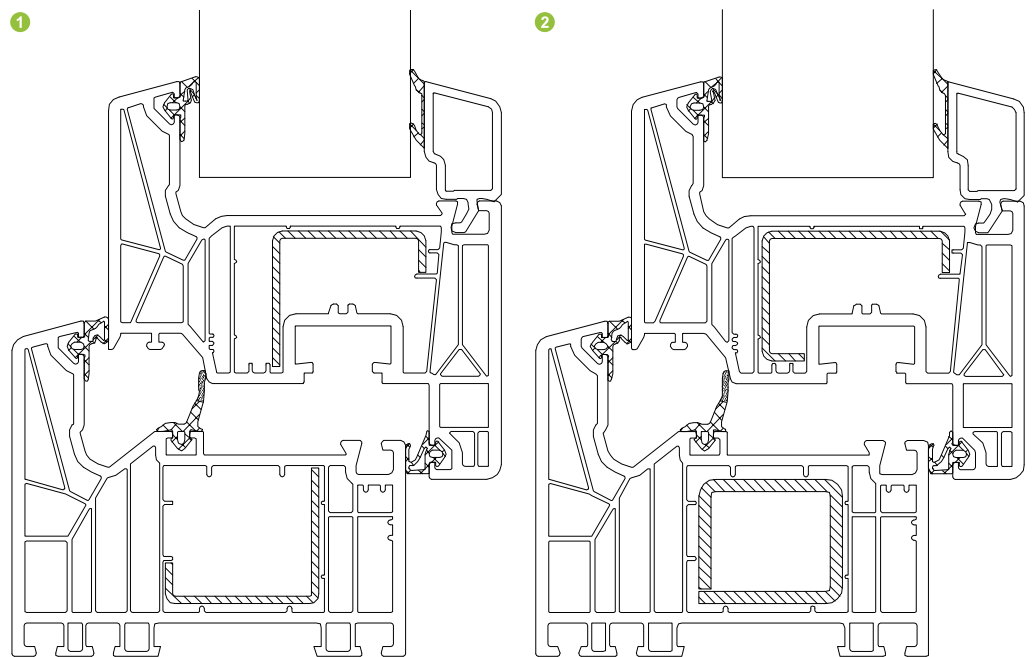

Schüco LivIng 82 MD mit Stahl 20271500 und 20271500
Prüfbericht 15-002325-PR 25
Schüco LivIng 82 MD with steel 20271500 and 20271500
Test report 15-002325-PR 25

Schüco LivIng 82 MD mit Stahl 20271900 und 20272500
Siehe Prüfbericht System U-Wert
Schüco LivIng with steel 20271900 and 20272500
See U value test report for system

Randverbund Edge seal	Psi (W/mK)	U_f (W/m ² K)	
		①	②
$U_g = 0,7$ (W/m²K)		0,96	1,0
		U_w (W/m²K)	
Alu Aluminium	0,078	0,98	0,99
Edelstahl Stainless steel	0,050	0,91	0,92
Thermix	0,039	0,88	0,89
Swisspacer Advance	0,037	0,88	0,89
Swisspacer Ultimate*	0,024	0,84	0,86
$U_g = 0,5$ (W/m²K)			
Alu Aluminium	0,078	0,84	0,85
Edelstahl Stainless steel	0,050	0,77	0,79
Thermix	0,039	0,75	0,76
Swisspacer Advance	0,037	0,74	0,75
Swisspacer Ultimate*	0,024	0,71	0,72
$U_g = 0,4$ (W/m²K)			
Alu Aluminium	0,078	0,77	0,79
Edelstahl Stainless steel	0,050	0,70	0,72
Thermix	0,039	0,68	0,69
Swisspacer Advance	0,037	0,67	0,69
Swisspacer Ultimate*	0,024	0,64	0,65

*Psi-Wert für den Swisspacer Ultimate in Kombination mit dem System Schüco LivIng gemäß ift-Prüfzeugnis 15-000619-PR04

*Psi value for the Swisspacer Ultimate in combination with the Schüco LivIng system in accordance with ift test certificate 15-000619-PR04

Systemschnitt 1:1

System section detail 1:1

Schüco LivIng 82 AS

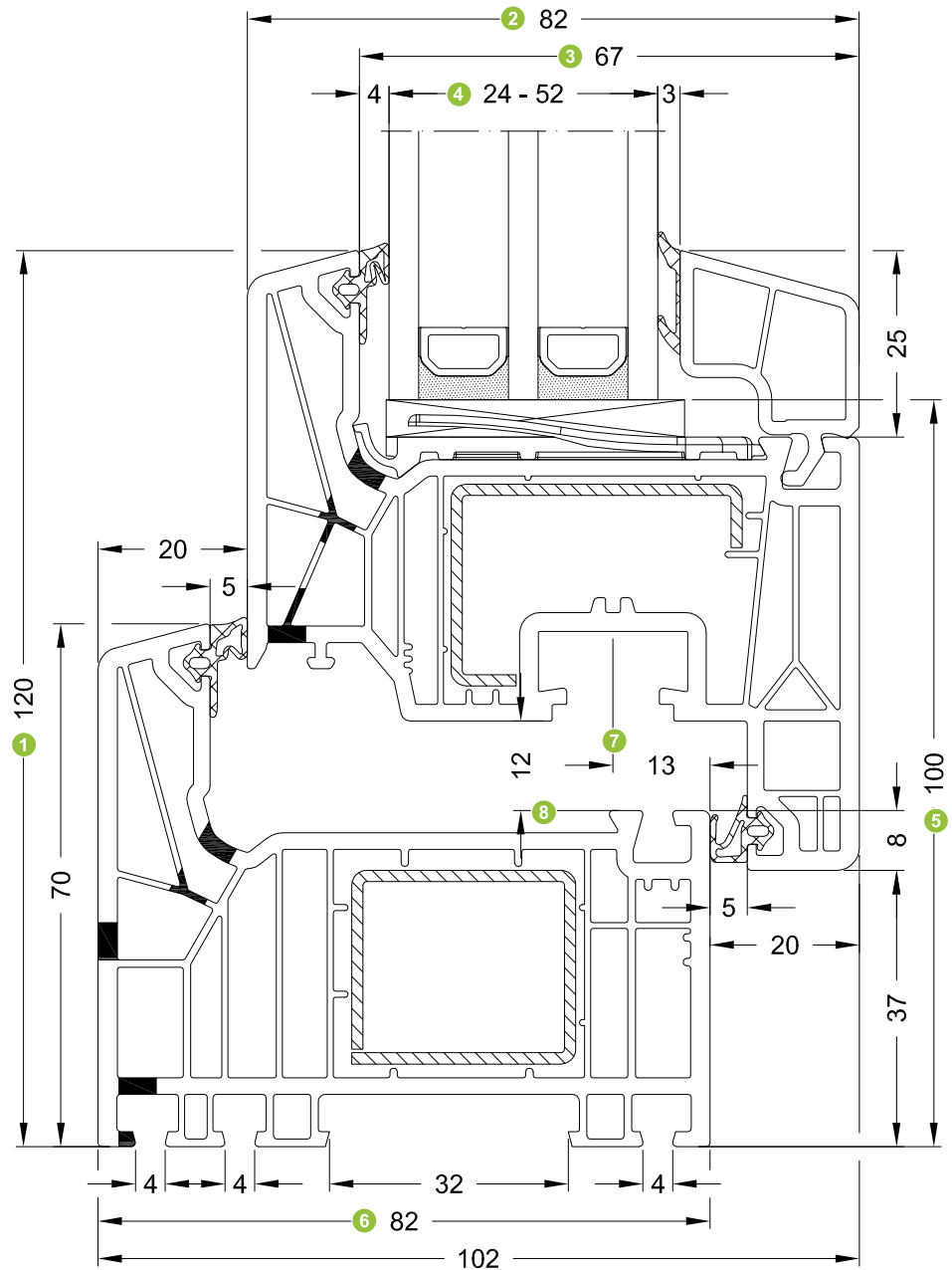

- | | | | |
|---|--|---|--|
| 1 | Ansichtsbreite
Face width | 5 | Glasabzugsmaß
Glass deduction |
| 2 | Flügelrahmen Bautiefe
Basic depth of vent frame | 6 | Blendrahmen Bautiefe
Basic depth of outer frame |
| 3 | Glasfalzbreite
Glazing rebate width | 7 | Achsmaß Beschlag
Axis dimension of fitting |
| 4 | Glasedicke
Glass thickness | 8 | Falzluftmaß
Rebate space dimension |

Schüco LivIng 82 MD

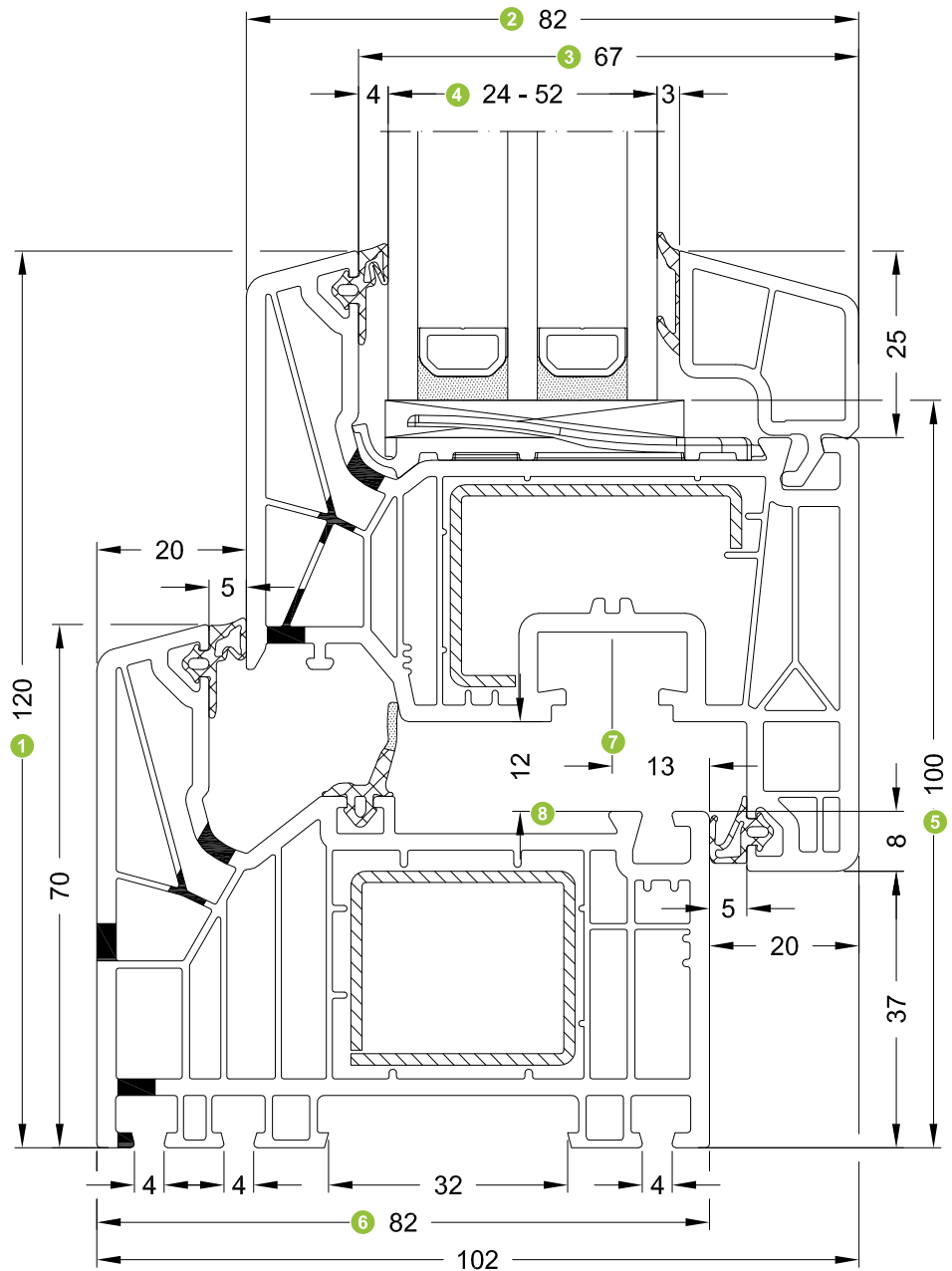

- | | | | |
|---|--|---|--|
| 1 | Ansichtsbreite
Face width | 5 | Glasabzugsmaß
Glass deduction |
| 2 | Flügelrahmen Bautiefe
Basic depth of vent frame | 6 | Blendrahmen Bautiefe
Basic depth of outer frame |
| 3 | Glasfalzbreite
Glazing rebate width | 7 | Achsmaß Beschlag
Axis dimension of fitting |
| 4 | Glasdicke
Glass thickness | 8 | Falzluftmaß
Rebate space dimension |

Elementtypenübersicht

Overview of unit types

Einteilige Fenster und Fenstertüren ■ Single-part windows and window doors

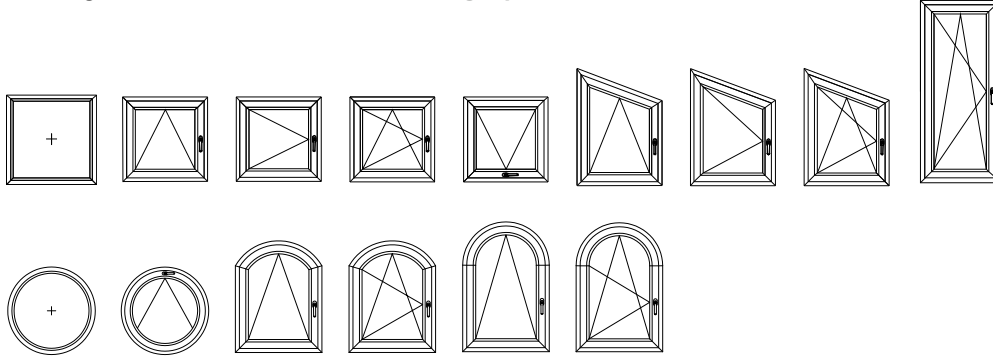

Mehrteilige Fenster und Fenstertüren ■ Multi-part windows and window doors

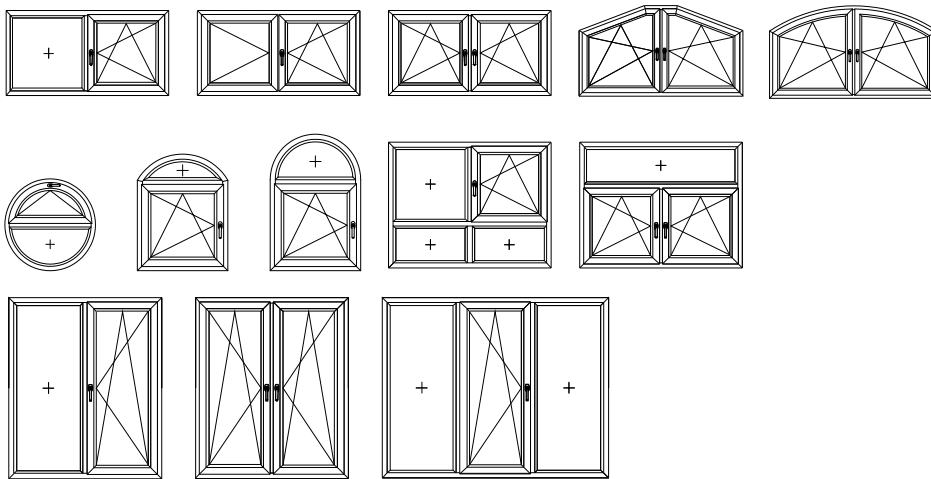

Nebeneingangstüren (NET) und Haustüren (HT)* ■ Side entrance doors (NET) and entrance doors (HT)*

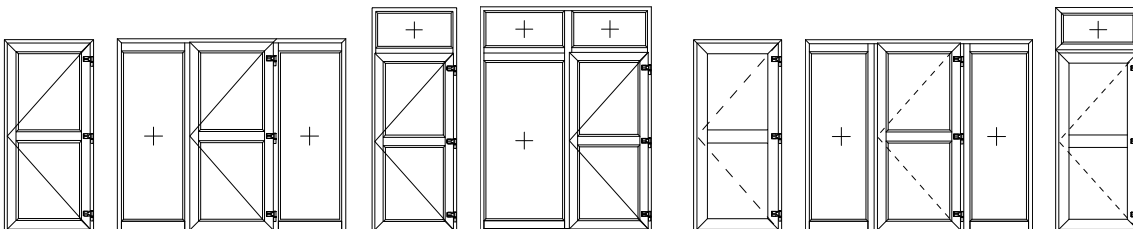

PASK-Fenster und Fenstertüren ■ Tilt/slide windows and window doors

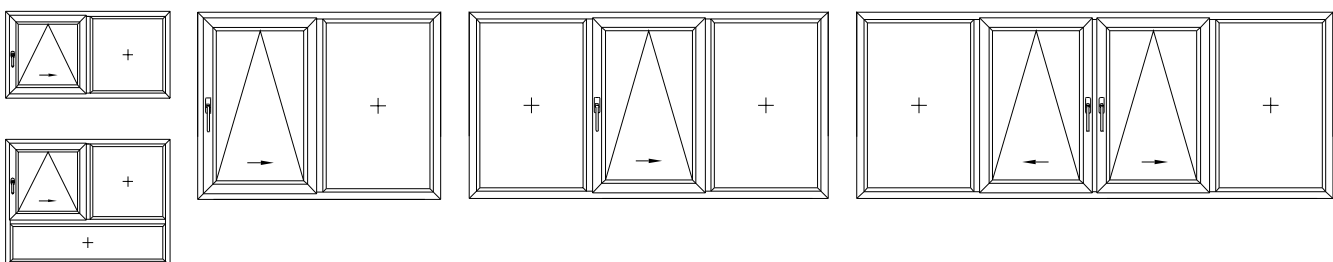

*Nebeneingangstüren und Haustüren können nur mit Schüco LivIng 82 AS gebaut werden.

*Side entrance doors and entrance doors can only be constructed using Schüco LivIng 82 AS.

Hinweise:

Die baubaren Größen in Verbindung mit Stahlverstärkungen sind aus den Tabellen „max. Flügelgrößen“ zu entnehmen.

Maximale Abmessungen für weiße Elemente:

Max. Profillänge: 4,00 m
Max. Fläche: 7,00 m²

Maximale Abmessungen für farbige Elemente:

Max. Profillänge (1-teilig): 2,5 m
Max. Profillänge (2-teilig): 2,8 m
Max. Profillänge (3-teilig): 3,0 m
Max. Fläche: 5,00 m²

Bei Festverglasungen darf ein Glasgewicht von 250 kg nicht überschritten werden.

Schrägelemente

Der kleinstmögliche Spitzenwinkel für Schrägfenster beträgt ca. 60°, hierbei sind jedoch folgende Punkte zu beachten.

Kammermaß = 12 + 1 mm

Aufgrund der geringen Spaltluft im Bereich des Scherenlagers kann es zu Funktionsstörungen beim schließen des Flügels kommen. Daher kann im Bereich der Spitze eine Vergrößerung des Kammermaßes nötig sein (durch beschneiden der Tropfkante).

Bewegliche Flügel müssen immer mit einem Auflaufbock oder Flügelheber ausgestattet sein.

Aufgrund von unterschiedlichen Beschlagdrehachsen und Verarbeitungstoleranzen sind im Grenzbereich vorab Versuche zur Bestimmung der max. Spitzenwinkel unumgänglich.

Es gelten die Allgemeinen Planungs- und Verarbeitungshinweise für Schüco Kunststoff-Systeme.

Note:

The sizes that can be constructed in conjunction with steel reinforcements can be found in the “Max. vent sizes” tables.

Maximum dimensions for white units:

Maximum profile length: 4.00 m
Maximum area: 7.00 m²

Maximum dimensions for coloured units:

Maximum profile length (1-part): 2.5 m
Maximum profile length (2-part): 2.8 m
Maximum profile length (3-part): 3.0 m
Maximum area: 5.00 m²

For fixed glazing, the glass weight must not exceed 250 kg.

Shaped units

The smallest possible point angle for shaped windows is approx. 60°. However, the following points must be noted:

Chamber size = 12 + 1 mm

Due to the minimal clearance around the turn/tilt mechanism pivot, the vent may malfunction when closing. It may therefore be necessary to increase the chamber size around the point angle (by cutting the drip edge).

Moving vents must always be fitted with an engagement block or a vent adjuster.

Due to the different rotational axes of the fittings and fabrication tolerances, it is essential that tests be carried out in advance to determine the max. point angle in the limit range.

The general design and fabrication instructions for Schüco PVC-U systems apply.

Maximale Flügelgrößen

Maximum vent sizes

Schüco Living							
Maximale Flügelhöhen und die (möglichen) zugehörigen Flügelbreiten in mm Maximum vent heights and the (possible) associated vent widths in mm							
Öffnungsart Opening type	Windwiderstandsklasse Wind resistance class	Ohne Verstärkungsprofil Without reinforcing profile	Weiß White	Weiß geklebt** White, bonded**	Farbig Coloured	Farbig geklebt** Coloured, bonded**	Glasgewicht Glass weight
DK-Fenster (83) Turn/tilt window (83)	B3	1000 x 800	2500 x 1000	2600 x 900	2400 x 900	2500 x 1000	80*
Stulpfenster (83) Double-vent window (83)	B2		2500 x 900	2500 x 1100	2400 x 800	2500 x 1000	80*
DK-Balkontür (110) Turn/tilt balcony door (110)	B3		2600 x 1000	2600 x 1100	2500 x 900	2600 x 1000	100*
Stulpbalkontür (110) Double-leaf balcony door (110)	B2		2600 x 1000	2600 x 1100	2500 x 900	2600 x 1000	100*
PASK (110) Tilt/slide (110)	B3		2400 x 1800	2500 x 1800	2280 x 1800	2380 x 1800	150
Haustür (125) Entrance door (125)	B2		2350 x 1100		2200 x 1100		100
Stulp-Haustür (125) Double-leaf entrance door (125)	B2		2350 x 1000		2200 x 1000		90

* geklebt
* Bonded

** Additive Klebetechnik
** Additive adhesive technology

Schüco Living							
Maximale Flügelbreiten und die (möglichen) zugehörigen Flügelhöhen in mm Maximum vent widths and the (possible) associated vent heights in mm							
Öffnungsart Opening type	Windwiderstandsklasse Wind resistance class	Ohne Verstärkungsprofil Without reinforcing profile	Weiß White	Weiß geklebt** White, bonded**	Farbig Coloured	Farbig geklebt** Coloured, bonded**	Glasgewicht Glass weight
DK-Fenster (83) Turn/tilt window (83)	B3	800 x 1000	1400 x 1700	1500 x 1600	1300 x 1600	1400 x 1600	80*
Stulpfenster (83) Double-vent window (83)	B2		1400 x 1700	1400 x 1850	1300 x 1600	1300 x 1900	80*
DK-Balkontür (110) Turn/tilt balcony door (110)	B3		1500 x 1700	1500 x 1900	1400 x 1700	1500 x 1700	100*
Stulpbalkontür (110) Double-leaf balcony door (110)	B2		1400 x 1900	1400 x 2100	1300 x 1900	1300 x 2100	100*
PASK (110) Tilt/slide (110)	B3		1800 x 2400	1800 x 2500	1800 x 2280	1800 x 2380	150
Haustür (125) Entrance door (125)	B2		2350 x 1100		2200 x 1100		100
Stulp-Haustür (125) Double-leaf entrance door (125)	B2		2350 x 1000		2200 x 1000		90

* geklebt
* Bonded

** Additive Klebetechnik
** Additive adhesive technology

Eckfestigkeiten von geschweißten Fensterrahmen

Corner stability of welded window frames

Prüfung mittels Wagengerät nach RAL-GZ 716/1, Abschnitt I

Testing using displacement support carriages in accordance with RAL-GZ 716/1, section I

Geltungsbereich:
Geschweißte Fensterrahmen aus PVC, die mittels Mehr-Kopf-Schweißmaschinen hergestellt sind.

Scope:
welded PVC-U window frames fabricated using multi-head welding machines.

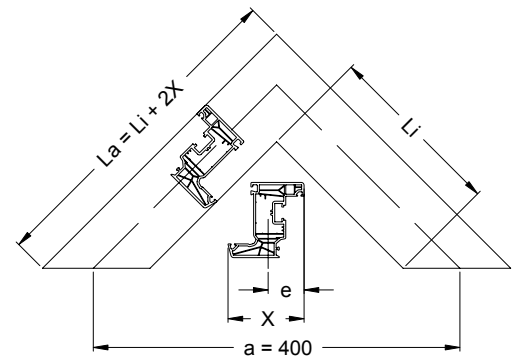
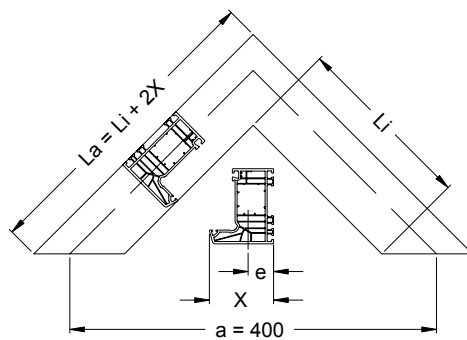

Eckfestigkeit Schüco LivIng

Corner stability Schüco LivIng

Art.-Nr. Art. No.	Abbildung Illustration	Ansichtsbreite Face width	Schenkellänge Leg length		Bruchkraft Breaking force F_{SOLL} (kN)
		(mm)	innen Inside L_1 (mm)	außen Outside L_2 (mm)	
19421...		70	199	339	2,82
19422...		80	189	349	3,96
19423...		90	179	359	5,30
19424...		100	170	370	6,51
19411...		70	200	340	2,91
19412...		80	190	350	4,09
19413...		90	180	360	5,48

Art.-Nr. Art. No.	Abbildung Illustration	Ansichtsbreite Face width	Schenkellänge Leg length		Bruchkraft Breaking force F_{SOLL} (kN)
		(mm)	innen Inside L_i (mm)	außen Outside L_a (mm)	
19430...		73	206	352	2,27
19431...		83	195	361	3,20
19434...		83	197	363	3,36
19432...		110	197	378	6,94
19433...		125	152	402	10,52
19452...		110	167	387	6,92
19453...		125	152	402	10,42

Art.-Nr. Art. No.	Abbildung Illustration	Ansichtsbreite Face width	Schenkellänge Leg length		Bruchkraft Breaking force
		(mm)	innen Inside L _i (mm)	außen Outside L _a (mm)	F _{SOLL} (kN)
19435...		103	186	392	9,70
19460...		72	211	355	1,96
19461...		92	191	375	3,89
19462...		112	171	395	6,68
19465...		92	191	375	4,07
19466...		112	171	395	7,01

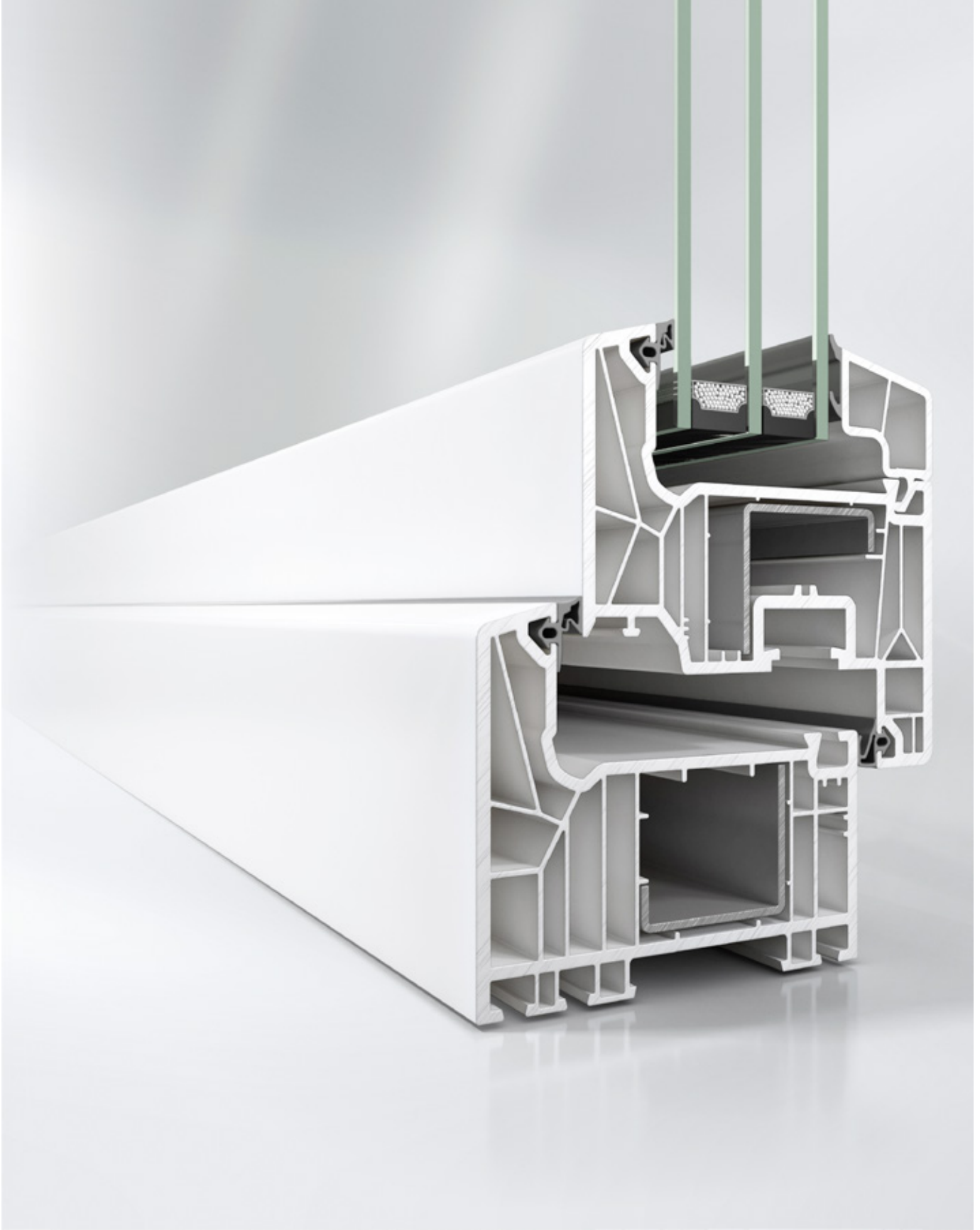

Profile
Profiles

- 23 Blendrahmen
Outer frames
- 31 Blendrahmen – Glasabzugsmaßtabellen
Outer frames – Glass deduction tables
- 33 Türschwelle
Door threshold
- 37 Flügelrahmen
Vent frames
- 46 Flügelrahmen – Glasabzugsmaßtabellen
Vent frames – Glass deduction tables
- 49 T-Profile und Sprossen
T-profiles and sash bars
- 55 T-Profile und Sprossen – Glasabzugsmaßtabellen
T-profiles and sash bars – Glass deduction tables
- 59 Stulpprofile
Double-vent profiles
- 64 Stulpprofile – Glasabzugsmaßtabellen
Double-vent profiles – Glass deduction tables
- 67 Zusatzprofile
Supplementary profiles

Blendrahmen Outer frames

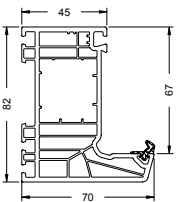
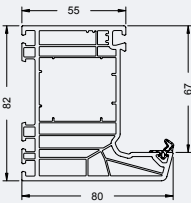
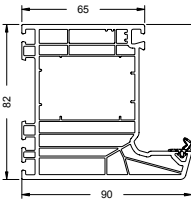
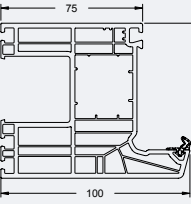
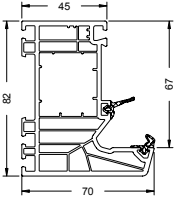
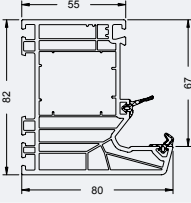
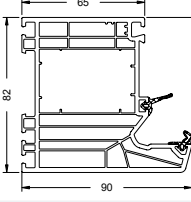
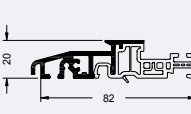
Art.-Nr. Art. No.	Abbildung Illustration	Benennung Description		
19421...		Blendrahmen 82/70 AS Outer frame 82/70 AS	AS	24
19422...		Blendrahmen 82/80 AS Outer frame 82/80 AS	AS	25
19423...		Blendrahmen 82/90 AS Outer frame 82/90 AS	AS	26
19424...		Blendrahmen 82/100 AS Outer frame 82/100 AS	AS	27
19411...		Blendrahmen 82/70 MD Outer frame 82/70 MD	MD	28
19412...		Blendrahmen 82/80 MD Outer frame 82/80 MD	MD	29
19413...		Blendrahmen 82/90 MD Outer frame 82/90 MD	MD	30
25255500 25255600		Türschwelle Living Living door threshold	AS / MD	33

Blendrahmen 82/70 AS ■ Outer frame 82/70 AS
19421...

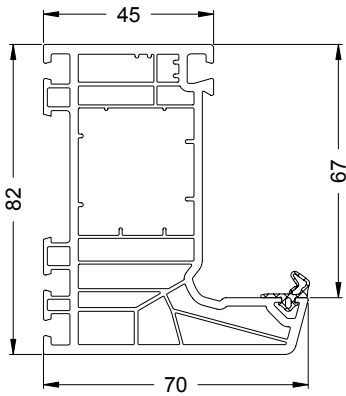

	20271500	20271700	20271800	20281200
l_x	1.34	2.01	2.94	1.17
l_y	0.68	1.6	2.33	2
t	1.5 mm	1.5 mm	2.5 mm	2.5 mm
x	6 m	6 m	6 m	6 m

Art.-Nr. Art. No.	Abbildung Illustration	Benennung Description			
25254600		Reparaturdichtung: Anschlag- und Glasanlagendichtung Repair gasket: rebate gasket and glazing rebate gasket	schwarz Black	100 m*	EPDM-Dichtung, polymerisiert, nicht schweißbar EPDM gasket, polymerised, cannot be welded
25254500			silbergrau Silver grey		
25094900		Klotzbrücke Glazing bridge	braun Brown	250 Stk.	Tragklotz für 3 mm Falztiefe Support block for 3 mm rebate depth
25094800		Klotzbrücke Glazing bridge	violett Violet	250 Stk.	Distanzklotz für 3 mm Falztiefe Spacer block for 3 mm rebate depth
24205900		Entwässerungskappe Drainage cover cap	weiß White	1000 Stk.	Weitere Ausführungen siehe Zubehör Foliensortiment For other designs, see the foil range in the Accessories section
25089000		Eindrehhanker Fixing lug	verzinkt Galvanised	100 Stk.	150 mm lang 150 mm long
25089500		Eindrehhanker Fixing lug	verzinkt Galvanised	100 Stk.	200 mm lang 200 mm long
28658200		Dämmprofil Blendrahmenrücken Insulation profile for rear of outer frame	—	70 Stk. x 1 m	kann vor Zuschnitt in Profil eingeschoben werden Can be inserted into the profile before cutting
25261300		Fensterfalzlüfter Schüco VentoAir RF LivIng 82 AS Schüco VentoAir RF LivIng 82 AS window rebate fan	weiß White	20 Stk.	Set aus Trägerbauteil, Flügelsystemdichtung grau, Rückstellfeder Kit comprises bracket components, grey vent system gasket, release spring

Blendrahmen 82/80 AS ■ Outer frame 82/80 AS
19422...

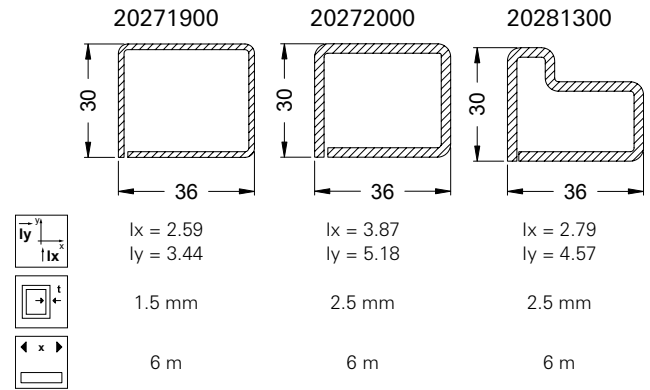
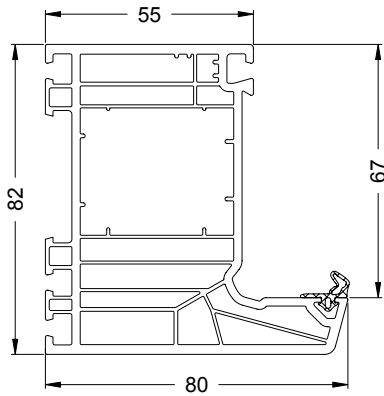

Art.-Nr. Art. No.	Abbildung Illustration	Benennung Description			
25254600		Reparaturdichtung: Anschlag- und Glasanlagedichtung	schwarz	100 m*	EPDM-Dichtung, polymerisiert, nicht schweißbar
25254500		Repair gasket: rebate gasket and glazing rebate gasket	silbergrau		
25094900		Klotzbrücke Glazing bridge	braun	250 Stk.	Tragklotz für 3 mm Falztiefe Support block for 3 mm rebate depth
25094800		Klotzbrücke Glazing bridge	violett	250 Stk.	Distanzklotz für 3 mm Falztiefe Spacer block for 3 mm rebate depth
24205900		Entwässerungskappe Drainage cover cap	weiß	1000 Stk.	Weitere Ausführungen siehe Zubehör Foliensortiment For other designs, see the foil range in the Accessories section
25089000		Eindrehanke Fixing lug	verzinkt	100 Stk.	150 mm lang 150 mm long
25089500		Eindrehanke Fixing lug	verzinkt	100 Stk.	200 mm lang 200 mm long
28658200		Dämmprofil Blendrahmenrücken Insulation profile for rear of outer frame	—	70 Stk. x 1 m	kann vor Zuschnitt in Profil eingeschoben werden Can be inserted into the profile before cutting
25261300		Fensterfalzlüfter Schüco VentoAir RF LivIng 82 AS Schüco VentoAir RF LivIng 82 AS window rebate fan	weiß	20 Stk.	Set aus Trägerbauteil, Flügelsystemdichtung grau, Rückstellfeder Kit comprises bracket components, grey vent system gasket, release spring

Blendrahmen 82/90 AS ■ Outer frame 82/90 AS
19423...

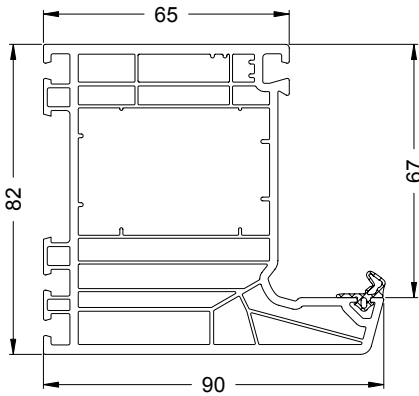

	20272100	20272200	20281400
	lx = 3.2 ly = 6.21	lx = 4.81 ly = 9.51	lx = 3.75 ly = 8.41
	1.5 mm	2.5 mm	2.5 mm
	6 m	6 m	6 m

Verfügbar ab 4. Quartal
Available from the 4th quarter

Art.-Nr. Art. No.	Abbildung Illustration	Benennung Description			
25254600		Reparaturdichtung: Anschlag- und Glasanlagendichtung Repair gasket: rebate gasket and glazing rebate gasket	schwarz Black	100 m*	EPDM-Dichtung, polymerisiert, nicht schweißbar EPDM gasket, polymerised, cannot be welded
25254500			silbergrau Silver grey		
25094900		Klotzbrücke Glazing bridge	braun Brown	250 Stk.	Tragklotz für 3 mm Falztiefe Support block for 3 mm rebate depth
25094800		Klotzbrücke Glazing bridge	violett Violet	250 Stk.	Distanzklotz für 3 mm Falztiefe Spacer block for 3 mm rebate depth
24205900		Entwässerungskappe Drainage cover cap	weiß White	1000 Stk.	Weitere Ausführungen siehe Zubehör Foliensortiment For other designs, see the foil range in the Accessories section
25089000		Eindrehhanker Fixing lug	verzinkt Galvanised	100 Stk.	150 mm lang 150 mm long
25089500		Eindrehhanker Fixing lug	verzinkt Galvanised	100 Stk.	200 mm lang 200 mm long
28658200		Dämmprofil Blendrahmenrücken Insulation profile for rear of outer frame	—	70 Stk. x 1 m	kann vor Zuschnitt in Profil eingeschoben werden Can be inserted into the profile before cutting
25261300		Fensterfalzlüfter Schüco VentoAir RF LivIng 82 AS Schüco VentoAir RF LivIng 82 AS window rebate fan	weiß White	20 Stk.	Set aus Trägerbauteil, Flügelsystemdichtung grau, Rückstellfeder Kit comprises bracket components, grey vent system gasket, release spring

Blendrahmen 82/100 AS ■ Outer frame 82/100 AS
19424...

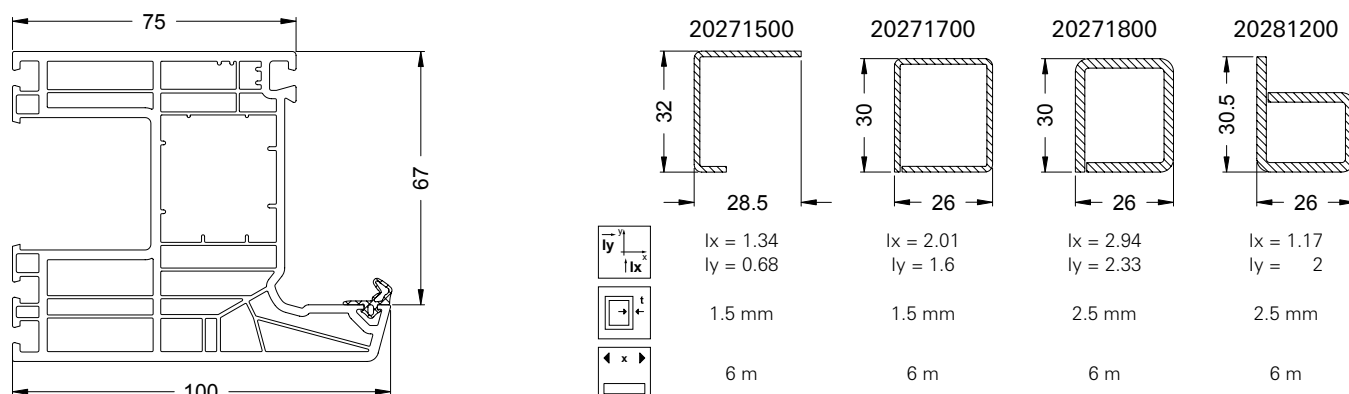

Art.-Nr. Art. No.	Abbildung Illustration	Benennung Description			
25254600		Reparaturdichtung: Anschlag- und Glasanlagendichtung Repair gasket: rebate gasket and glazing rebate gasket	schwarz Black	100 m*	EPDM-Dichtung, polymerisiert, nicht schweißbar EPDM gasket, polymerised, cannot be welded
25254500			silbergrau Silver grey		
25094900		Klotzbrücke Glazing bridge	braun Brown	250 Stk.	Tragklotz für 3 mm Falztiefe Support block for 3 mm rebate depth
25094800		Klotzbrücke Glazing bridge	violett Violet	250 Stk.	Distanzklotz für 3 mm Falztiefe Spacer block for 3 mm rebate depth
24205900		Entwässerungskappe Drainage cover cap	weiß White	1000 Stk.	Weitere Ausführungen siehe Zubehör Foliensortiment For other designs, see the foil range in the Accessories section
25089000		Eindrehanker Fixing lug	verzinkt Galvanised	100 Stk.	150 mm lang 150 mm long
25089500		Eindrehanker Fixing lug	verzinkt Galvanised	100 Stk.	200 mm lang 200 mm long
25261300		Fensterfalzlüfter Schüco VentoAir RF LivIng 82 AS Schüco VentoAir RF LivIng 82 AS window rebate fan	weiß White	20 Stk.	Set aus Trägerbauteil, Flügelsystemdichtung grau, Rückstellfeder Kit comprises bracket components, grey vent system gasket, release spring



Blendrahmen 82/70 MD ■ Outer frame 82/70 MD
19411...

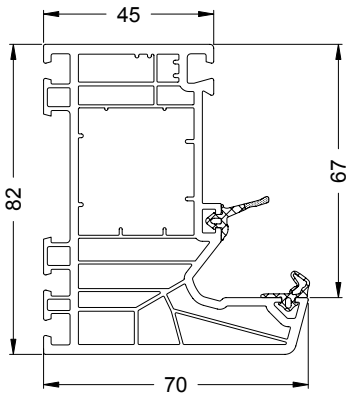

	20271500	20271700	20271800	20281200
	lx = 1.34 ly = 0.68	lx = 2.01 ly = 1.6	lx = 2.94 ly = 2.33	lx = 1.17 ly = 2
	1.5 mm	1.5 mm	2.5 mm	2.5 mm
	6 m	6 m	6 m	6 m

Art.-Nr. Art. No.	Abbildung Illustration	Benennung Description			
25254600		Reparaturdichtung: Anschlag- und Glasanlagendichtung Repair gasket: rebate gasket and glazing rebate gasket	schwarz Black	100 m*	EPDM-Dichtung, polymerisiert, nicht schweißbar EPDM gasket, polymerised, cannot be welded
25254500		Reparaturdichtung: Anschlag- und Glasanlagendichtung Repair gasket: rebate gasket and glazing rebate gasket	silbergrau Silver grey		
25254000		Reparaturdichtung: Mitteldichtung Repair gasket: centre gasket	schwarz Black	100 m*	EPDM-Dichtung, polymerisiert, nicht schweißbar EPDM gasket, polymerised, cannot be welded
25253900		Reparaturdichtung: Mitteldichtung Repair gasket: centre gasket	silbergrau Silver grey		
25094700		Klotzbrücke Glazing bridge	orange Orange	250 Stk.	Trag- und Distanzklotz für 3 mm Falztiefe Support and spacer block for 3 mm rebate depth
24205900		Entwässerungskappe Drainage cover cap	weiß White	1000 Stk.	Weitere Ausführungen siehe Zubehör Foliensortiment For other designs, see the foil range in the Accessories section
25089000		Eindrehanker Fixing lug	verzinkt Galvanised	100 Stk.	150 mm lang 150 mm long
25089500		Eindrehanker Fixing lug	verzinkt Galvanised	100 Stk.	200 mm lang 200 mm long
28658200		Dämmprofil Blendrahmenrücken Insulation profile for rear of outer frame	—	70 Stk. x 1 m	kann vor Zuschnitt in Profil eingeschoben werden Can be inserted into the profile before cutting
25261400		Fensterfalzlüfter Schüco VentoAir RF LivIng 82 MD Schüco VentoAir RF LivIng 82 MD window rebate fan	weiß White	20 Stk.	Set aus Trägerbauteil, Flügelsystemdichtung grau, Rückstellfeder Kit comprises bracket components, grey vent system gasket, release spring

Blendrahmen 82/80 MD ■ Outer frame 82/80 MD
19412...

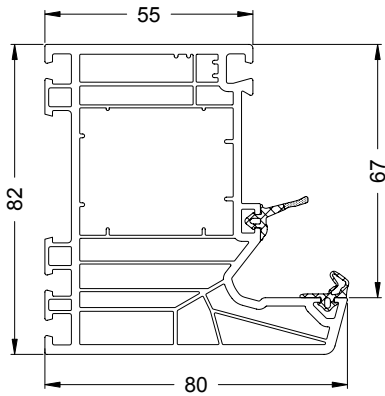

	20271900	20272000	20281300
l_x	2.59	3.87	2.79
l_y	3.44	5.18	4.57
t	1.5 mm	2.5 mm	2.5 mm
x	6 m	6 m	6 m

Art.-Nr. Art. No.	Abbildung Illustration	Benennung Description			
25254600		Reparaturdichtung: Anschlag- und Glasanlagedichtung Repair gasket: rebate gasket and glazing rebate gasket	schwarz Black	100 m*	EPDM-Dichtung, polymerisiert, nicht schweißbar EPDM gasket, polymerised, cannot be welded
25254500			silbergrau Silver grey		
25254000		Reparaturdichtung: Mitteldichtung Repair gasket: centre gasket	schwarz Black	100 m*	EPDM-Dichtung, polymerisiert, nicht schweißbar EPDM gasket, polymerised, cannot be welded
25253900			silbergrau Silver grey		
25094700		Klotzbrücke Glazing bridge	orange Orange	250 Stk.	Trag- und Distanzklotz für 3 mm Falztiefe Support and spacer block for 3 mm rebate depth
24205900		Entwässerungskappe Drainage cover cap	weiß White	1000 Stk.	Weitere Ausführungen siehe Zubehör Foliensortiment For other designs, see the foil range in the Accessories section
25089000		Eindrehanke Fixing lug	verzinkt Galvanised	100 Stk.	150 mm lang 150 mm long
25089500		Eindrehanke Fixing lug	verzinkt Galvanised	100 Stk.	200 mm lang 200 mm long
28658200		Dämmprofil Blendrahmenrücken Insulation profile for rear of outer frame	—	70 Stk. x 1 m	kann vor Zuschnitt in Profil eingeschoben werden Can be inserted into the profile before cutting
25261400		Fensterfalzlüfter Schüco VentoAir RF LivIng 82 MD Schüco VentoAir RF LivIng 82 MD window rebate fan	weiß White	20 Stk.	Set aus Trägerbauteil, Flügelsystemdichtung grau, Rückstellfeder Kit comprises bracket components, grey vent system gasket, release spring

Blendrahmen 82/90 MD ■ Outer frame 82/90 MD
19413...

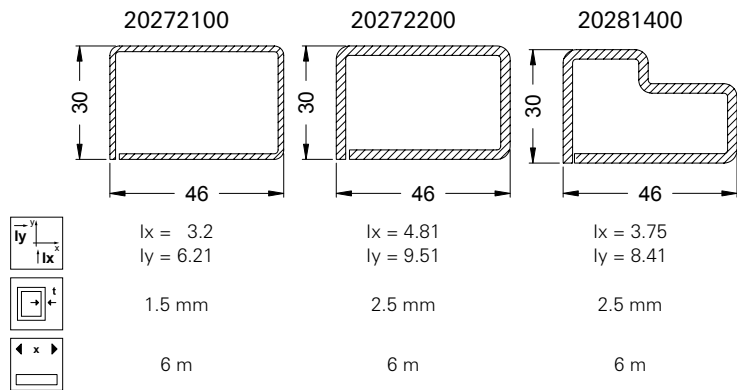
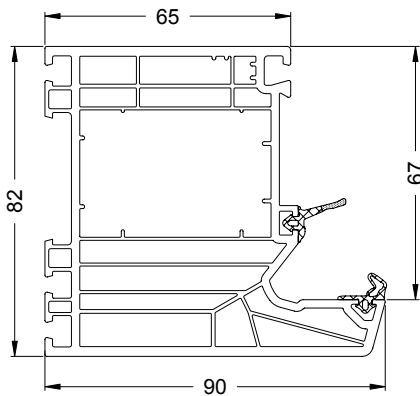

Art.-Nr. Art. No.	Abbildung Illustration	Benennung Description			
25254600		Reparaturdichtung: Anschlag- und Glasanlagendichtung Repair gasket: rebate gasket and glazing rebate gasket	schwarz Black	100 m*	EPDM-Dichtung, polymerisiert, nicht schweißbar EPDM gasket, polymerised, cannot be welded
25254500		Reparaturdichtung: Anschlag- und Glasanlagendichtung Repair gasket: rebate gasket and glazing rebate gasket	silbergrau Silver grey		
25254000		Reparaturdichtung: Mitteldichtung Repair gasket: centre gasket	schwarz Black	100 m*	EPDM-Dichtung, polymerisiert, nicht schweißbar EPDM gasket, polymerised, cannot be welded
25253900		Reparaturdichtung: Mitteldichtung Repair gasket: centre gasket	silbergrau Silver grey		
25094700		Klotzbrücke Glazing bridge	orange Orange	250 Stk.	Trag- und Distanzklotz für 3 mm Falztiefe Support and spacer block for 3 mm rebate depth
24205900		Entwässerungskappe Drainage cover cap	weiß White	1000 Stk.	Weitere Ausführungen siehe Zubehör Foliensortiment For other designs, see the foil range in the Accessories section
25089000		Eindrehanker Fixing lug	verzinkt Galvanised	100 Stk.	150 mm lang 150 mm long
25089500		Eindrehanker Fixing lug	verzinkt Galvanised	100 Stk.	200 mm lang 200 mm long
28658200		Dämmprofil Blendrahmenrücken Insulation profile for rear of outer frame	—	70 Stk. x 1 m	kann vor Zuschnitt in Profil eingeschoben werden Can be inserted into the profile before cutting
25261400		Fensterfalzlüfter Schüco VentoAir RF LivIng 82 MD Schüco VentoAir RF LivIng 82 MD window rebate fan	weiß White	20 Stk.	Set aus Trägerbauteil, Flügelsystemdichtung grau, Rückstellfeder Kit comprises bracket components, grey vent system gasket, release spring

Glasabzugsmaßtabellen

Glass deduction tables

Blendrahmen ■ Outer frame

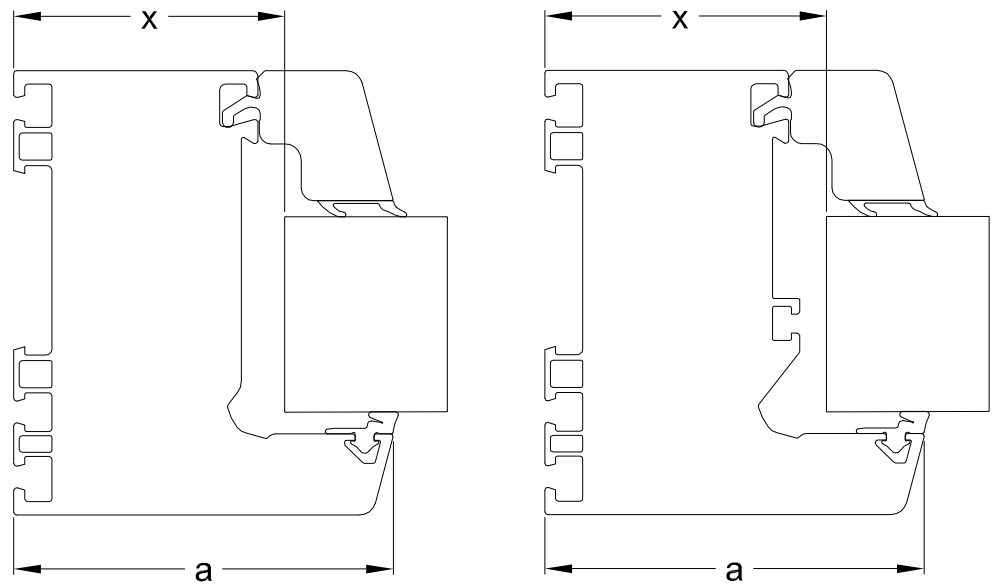

Gesamtansichtsmaß (a) Total face width (a)	70 mm	80 mm	90 mm	100 mm
Glasabzugsmaß (x) Glass deduction (x)				
AS	50	60	70	80
MD	52	62	72	82

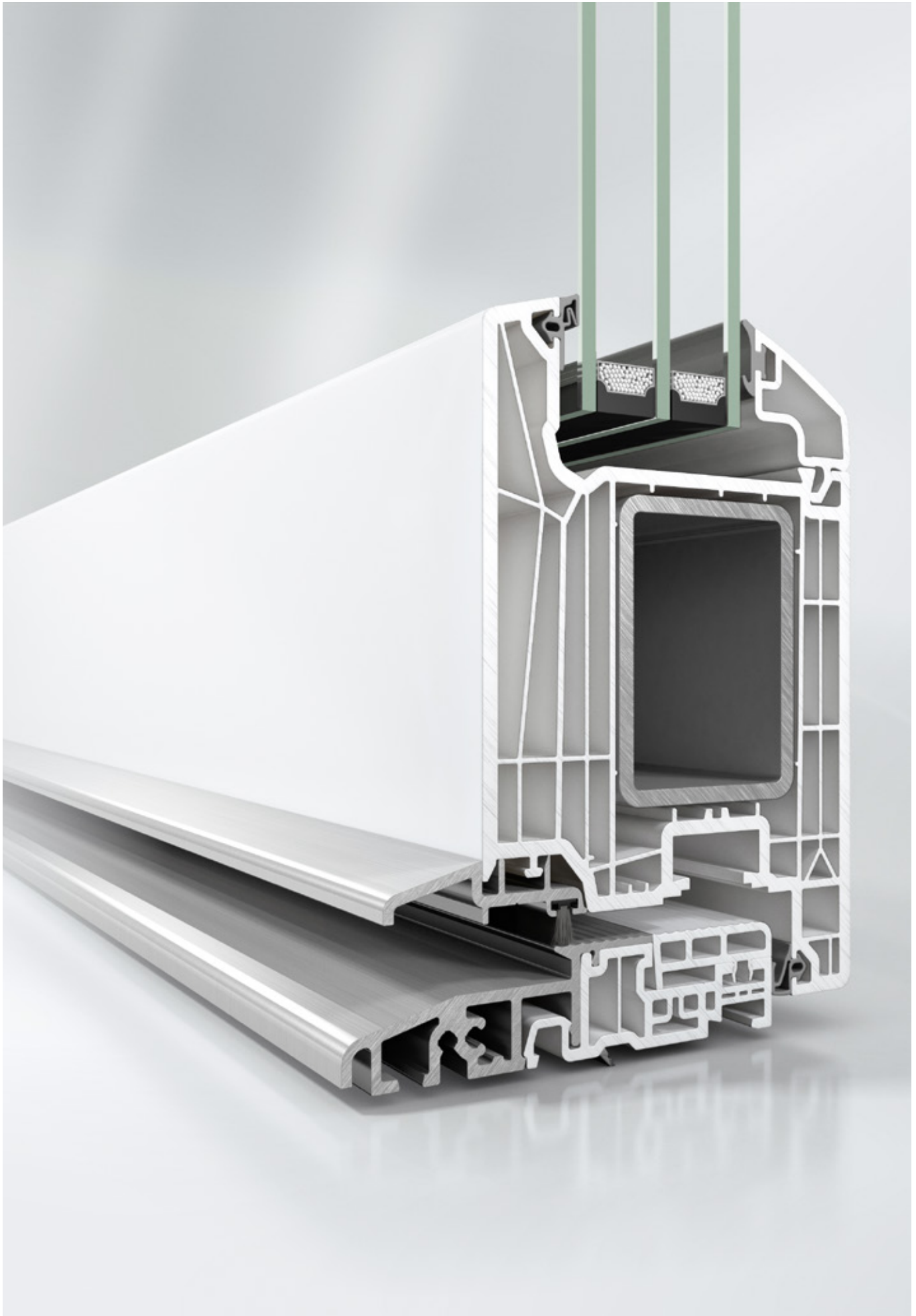

Türschwelle

Door threshold

Türschwelle LivIng ■ LivIng door threshold









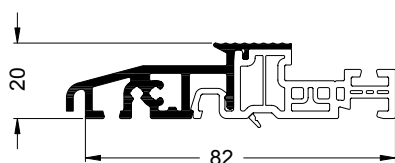









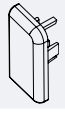





Türschwelle durchlaufend
Door threshold, continuous

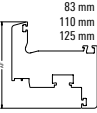

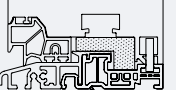

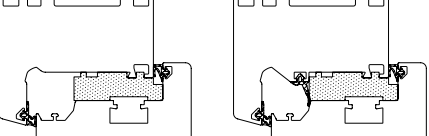

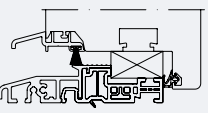
25255500 ALU E6/EV1
PVC grau ■ Grey

25255600 ALU schwarz ■ Black
PVC schwarz ■ Black

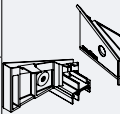
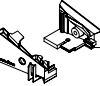
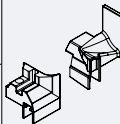
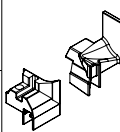

Art.-Nr. Art. No.	Abbildung Illustration	Benennung Description			
17472060		Trittschutz, einwärts Kick plate, inwards	grau Grey	6,0 m	zur Abdeckung des Türschwelfalzes To cover the door threshold rebate
17472150		Trittschutz, einwärts Kick plate, inwards	schwarz Black		
17474060		Trittschutz, auswärts Kick plate, outwards	grau Grey	6,0 m	zur Abdeckung des Türschwelfalzes To cover the door threshold rebate
17474150		Trittschutz, auswärts Kick plate, outwards	schwarz Black		
25061800		Anschlagdichtung Rebate gasket	silbergrau Silver grey	50 m*	Anschlagdichtung für oberen Teil des Flügelrahmens, für auswärts öffnende Türen Rebate gasket for upper part of the leaf frame, for outward-opening doors
25061700		Anschlagdichtung Rebate gasket	schwarz Black		
25264800		Türschwelenhalter 70 mm Door threshold bracket 70 mm	weiß White	10 P.	Für Blendrahmen 70 For outer frame 70
25264900		Türschwelenhalter 70 mm Door threshold bracket 70 mm	schwarz Black		
25265000		Türschwelenhalter 80 mm Door threshold bracket 80 mm	weiß White	10 P.	Für Blendrahmen 80 For outer frame 80
25265100		Türschwelenhalter 80 mm Door threshold bracket 80 mm	schwarz Black		
25265200		Türschwelenhalter 90 mm Door threshold bracket 90 mm	weiß White	10 P.	Für Blendrahmen 90 For outer frame 90
25265300		Türschwelenhalter 90 mm Door threshold bracket 90 mm	schwarz Black		
25265400		Türschwelenhalter 100 mm Door threshold bracket 100 mm	weiß White	10 P.	Für Blendrahmen 100 For outer frame 100
25265500		Türschwelenhalter 100 mm Door threshold bracket 100 mm	schwarz Black		
25064500		Türschwelendichtung Door threshold gasket	silbergrau Silver grey	5 x 1,20 m	Optionale Dichtung für die Beschlagnut Optional gasket for the fittings groove
14709500			roh mill finish		
14709510		Bürstenaufnahme LivIng Living brush seal groove	weiß White	6 m	für innen öffnend (in Kombination mit Wetterschenkel) und außen öffnend (ohne Wetterschenkel) For inward-opening (in conjunction with drip bar) and outward-opening (without drip bar)
14709560		Bürstenaufnahme LivIng Living brush seal groove	E6/EV1		
14709570			schwarz Black		
25266000		Dichtset MD MD seal kit	schwarz Black	10 Stk.	Inhalt des Sets ist je ein linker und ein rechter Dichtstopfen und je eine linke und rechte Endkappe (dargestellt ist je ein rechtes Teil) Each set contains a left-hand and right-hand sealing plug and a left-hand and right-hand end cap (a right-hand component is shown in each case)
25266100		Dichtset MD MD seal kit	silbergrau Silver grey		
25266200		Dichtset AS AS seal kit	schwarz Black	5 Stk.	Inhalt des Sets ist je ein linker und ein rechter Windstopp für den Blendrahmen und den Flügelrahmen (dargestellt ist je ein rechtes Teil) Each set contains a left-hand and right-hand wind stop for the outer frame and the vent frame (a right-hand component is shown in each case)
25266300		Dichtset AS AS seal kit	silbergrau Silver grey		

Art.-Nr. Art. No.	Abbildung Illustration	Benennung Description			
14709600		Alu-Wetterschenkel 38,7/10,5 Aluminium drip bar 38.7/10.5	roh mill finish	6 m	Im Kapitel "Zusatzprofile" befinden sich weitere Wetterschenkel/ Endkappen/Zubehör. Further drip bars / end caps / accessories can be found in the chapter "Supplementary profiles".
14709610			weiß White		
14709660			E6/EV1		
14709670			schwarz Black		
28634100		Endkappe End cap	weiß White	5 P.	Im Kapitel "Zusatzprofile" befinden sich weitere Wetterschenkel/ Endkappen/Zubehör. Further drip bars / end caps / accessories can be found in the chapter "Supplementary profiles".
28696400			cremeweiß Cream white		
28696200			karamell Caramel		
28696300			braun Brown		
28634200			schwarz Black		
17494...		Wetterschenkel 19,5/32 Drip bar 19.5/32	—	6,0 m	Im Kapitel "Zusatzprofile" befinden sich weitere Wetterschenkel/ Endkappen/Zubehör. Further drip bars / end caps / accessories can be found in the chapter "Supplementary profiles".
21794600		Dicht- bzw. Endkappe Sealing/end cap	weiß White	25 P.	Im Kapitel "Zusatzprofile" befinden sich weitere Wetterschenkel/ Endkappen/Zubehör. Further drip bars / end caps / accessories can be found in the chapter "Supplementary profiles".
11394900		Alu-Adapter 10/4, gelocht (roh) Aluminium adapter 10/4, pre-punched (mill finish)	roh mill finish	6,0 m	Im Kapitel "Zusatzprofile" befinden sich weitere Wetterschenkel/ Endkappen/Zubehör. Further drip bars / end caps / accessories can be found in the chapter "Supplementary profiles".
28699300		Bürstendichtung 9 Brush seal 9	schwarz Black	100 m*	Einsatz als Dichtung für Türschwellen bei 5 mm Bodenabstand (Abstand Flügelunterkante zur Oberkante Fertigfußboden) Use as gasket for door thresholds with 5 mm distance from the ground (distance from bottom edge of the leaf to finished floor level)
28699400		Bürstendichtung 11 Brush seal 11	schwarz Black	100 m*	Einsatz als Dichtung für Türschwellen bei 7 mm Bodenabstand (Abstand Flügelunterkante zur Oberkante Fertigfußboden) Use as gasket for door thresholds with 7 mm ground clearance (dis- tance from bottom edge of the leaf to finished floor level)
Mehrteilige Elemente Multi-part units					
25265600		Pfostenhalter 92 mm Mullion bracket 92 mm	weiß White	10 Stk.	Für T-Profil 92 For T-profile 92
25265700			schwarz Black		
25265800		Pfostenhalter 112 mm Mullion bracket 112 mm	weiß White	10 Stk.	Für T-Profil 112 For T-profile 112
25265900			schwarz Black		
19838...		Wetterschenkel LivIng LivIng drip bar	—	6 m	Im Kapitel "Zusatzprofile" befinden sich weitere Wetterschenkel/ Endkappen/Zubehör. Further drip bars / end caps / accessories can be found in the chapter "Supplementary profiles".
17609020		Passfeder 4/14 Spring pin 4/14	—	—	Im Kapitel "Zusatzprofile" befinden sich weitere Wetterschenkel/ Endkappen/Zubehör. Further drip bars / end caps / accessories can be found in the chapter "Supplementary profiles".
—		Eingeschraubter Flügelrahmen, Festfeld Screwed-in leaf frame, fixed light	—	—	Hinweis: Für den Einsatz als Aufbauprofil, muss der Flügelrahmen vor der Verarbeitung beschnitten werden. Note: For use as a built-on profile, the leaf frame must be cut to size before fabrication.
25260600		KS-Distanzklotz Festfeld Plastic spacer block for fixed light	grau Grey	20 Stk.	
23752200		Distanzstück Spacer	schwarz Black	20 Stk.	
—		Distanzklotz Spacer block	28 x 12	—	
—			28 x 14		

Art.-Nr. Art. No.	Abbildung Illustration	Benennung Description			
Stulp-Türen Double-leaf doors					
25088500		Distanzstück Spacer	schwarz Black	20 Stk.	—
25266800		Stulp Set LivIng 82 AS - RS LivIng 82 AS meeting stile kit - RH	schwarz Black	5 Stk.	Inhalt des Sets ist je ein Windstopp für den Stulp und ein Windstopp für den Flügelrahmen Each set contains a wind stop for the meeting stile and a wind stop for the leaf frame
25266900			silbergrau Silver grey		
25267000		Stulp Set LivIng 82 AS - LS LivIng 82 AS meeting stile kit - LH	schwarz Black	5 Stk.	Inhalt des Sets ist je ein Windstopp für den Stulp und ein Windstopp für den Flügelrahmen Each set contains a wind stop for the meeting stile and a wind stop for the leaf frame
25267100			silbergrau Silver grey		
25266400		Stulp Set LivIng SI 82 MD - RS LivIng SI 82 MD meeting stile kit - RH	schwarz Black	5 Stk.	rechts Right Inhalt des Sets ist je ein Stulpdichtstück und eine Endkappe Each set contains a meeting stile seal and an end cap
25266500			silbergrau Silver grey		
25266600		Stulp Set LivIng SI 82 MD - LS LivIng SI 82 MD meeting stile kit - LH	schwarz Black	—	links Left Inhalt des Sets ist je ein Stulpdichtstück und eine Endkappe Each set contains a meeting stile seal and an end cap
25266700			silbergrau Silver grey		
Zubehör Accessories					
—		—	—	—	Hinweis: Wetterschenkel, Trittschutzprofile und Zubehör siehe "Zusatzprofile" Note: See "Supplementary profiles" for drip bars, kick plate profiles and accessories

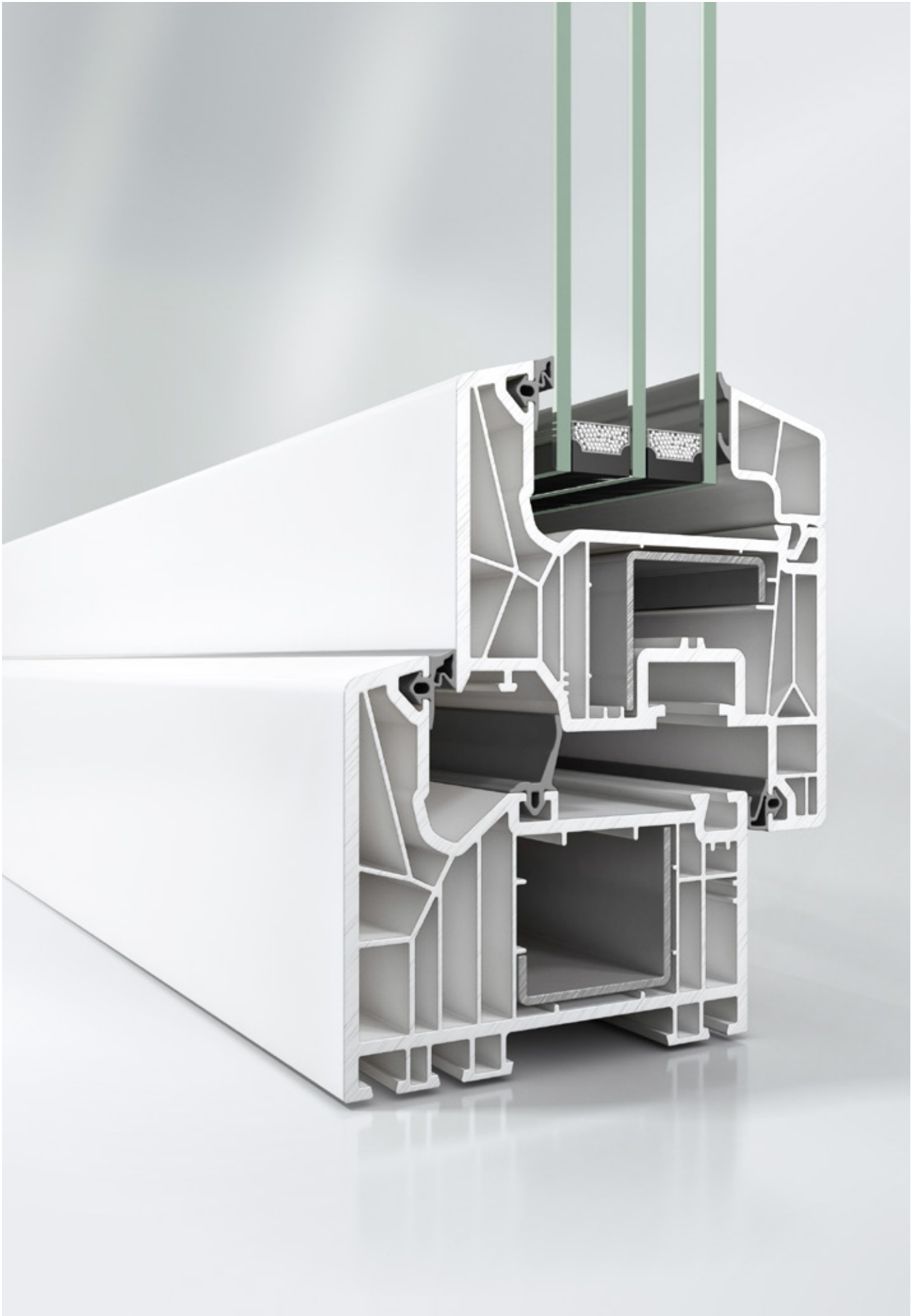

Flügelrahmen Vent frames

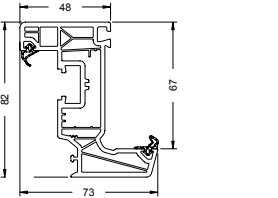
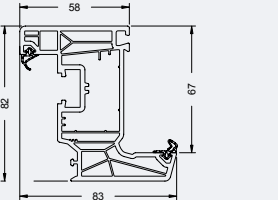
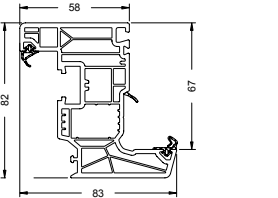
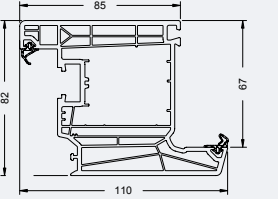
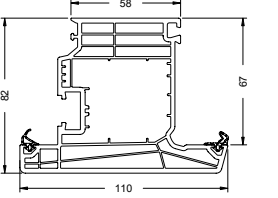
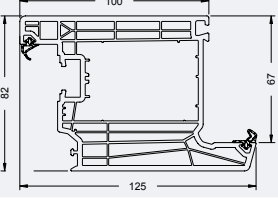
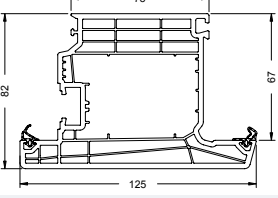
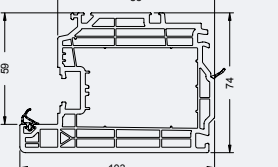
Art.-Nr. Art. No.	Abbildung Illustration	Benennung Description			
19430...		Flügelrahmen 82/73 Vent frame 82/73	AS MD		38
19431...		Flügelrahmen 82/83 Vent frame 82/83	AS MD		39
19434...		Flügelrahmen 82/83 Klebeflügel Vent frame 82/83 for adhesive vent	AS MD		40
19432...		Flügelrahmen 82/110 Vent frame 82/110	AS MD	NET AS	41
19452...		Flügelrahmen 82/110 nach außen öffnend Vent frame 82/110, outward-opening	— NET AS		42
19433...		Flügelrahmen 82/125 Vent frame 82/125	— HT AS		43
19453...		Flügelrahmen 82/125 nach außen öffnend Vent frame 82/125, outward-opening	— HT AS		44
19435...		Flügelrahmen 82/103 Vent frame 82/103	— HT AS		45

Flügelrahmen 82/73 ■ Vent frame 82/73
19430...

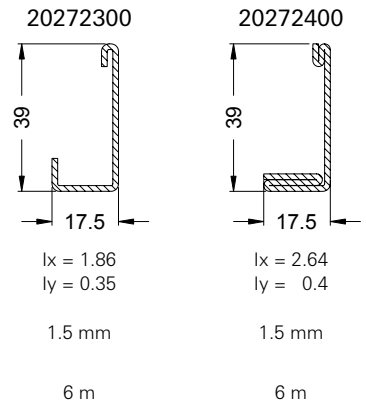
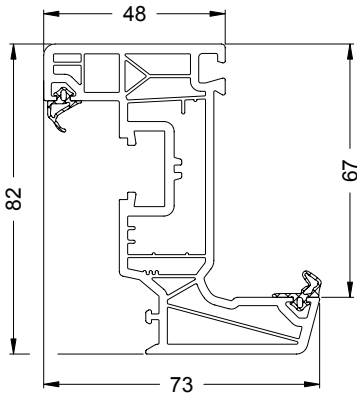

Art.-Nr. Art. No.	Abbildung Illustration	Benennung Description			
25254600		Reparaturdichtung: Anschlag- und Glasanlagendichtung Repair gasket: rebate gasket and glazing rebate gasket	schwarz Black	100 m*	EPDM-Dichtung, polymerisiert, nicht schweißbar EPDM gasket, polymerised, cannot be welded
25254500		Reparaturdichtung: Anschlag- und Glasanlagendichtung Repair gasket: rebate gasket and glazing rebate gasket	silbergrau Silver grey		
25255000		Reparaturdichtung: Flügelanschlagdichtung Repair gasket: vent rebate gasket	schwarz Black	100 m*	EPDM-Dichtung, polymerisiert, nicht schweißbar EPDM gasket, polymerised, cannot be welded
25254900		Reparaturdichtung: Flügelanschlagdichtung Repair gasket: vent rebate gasket	silbergrau Silver grey		
25094900		Klotzbrücke Glazing bridge	braun Brown	250 Stk.	Tragklotz für 3 mm Falztiefe Support block for 3 mm rebate depth
25094800		Klotzbrücke Glazing bridge	violett Violet	250 Stk.	Distanzklotz für 3 mm Falztiefe Spacer block for 3 mm rebate depth
25264700		Dämmfalzeinleger 67 LivIng LivIng insulating rebate insert 67	—	80 m	—
19640000		Falzeinlage 67/3 Rebate insert 67/3	weiß White	3 x 6 m	Einsetzbar bei Schüco LivIng Can be used with Schüco LivIng

Flügelrahmen 82/83 ■ Vent frame 82/83
19431...

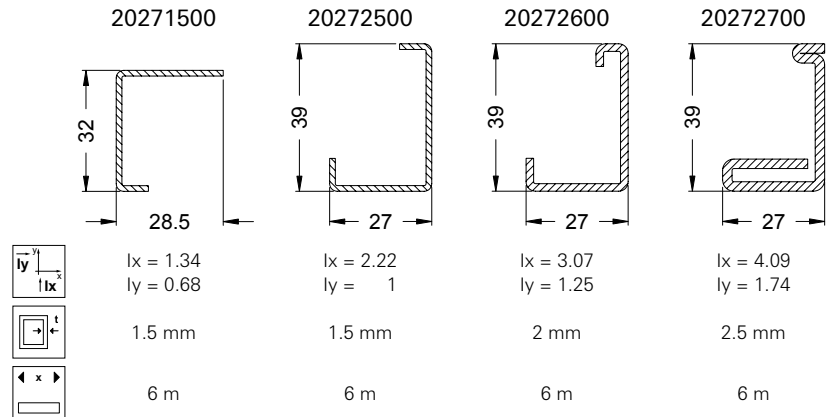
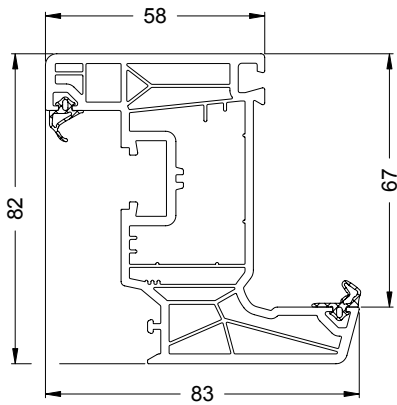

Art.-Nr. Art. No.	Abbildung Illustration	Benennung Description			
25254600		Reparaturdichtung: Anschlag- und Glasanlagedichtung Repair gasket: rebate gasket and glazing rebate gasket	schwarz Black	100 m*	EPDM-Dichtung, polymerisiert, nicht schweißbar EPDM gasket, polymerised, cannot be welded
25254500			silbergrau Silver grey		
25255000		Reparaturdichtung: Flügelanschlagdichtung Repair gasket: vent rebate gasket	schwarz Black	100 m*	EPDM-Dichtung, polymerisiert, nicht schweißbar EPDM gasket, polymerised, cannot be welded
25254900			silbergrau Silver grey		
25094900		Klotzbrücke Glazing bridge	braun Brown	250 Stk.	Tragklotz für 3 mm Falztiefe Support block for 3 mm rebate depth
25094800		Klotzbrücke Glazing bridge	violett Violet	250 Stk.	Distanzklotz für 3 mm Falztiefe Spacer block for 3 mm rebate depth
25264700		Dämmfalzeinleger 67 LivIng LivIng insulating rebate insert 67	—	80 m	—
19640000		Falzeinlage 67/3 Rebate insert 67/3	weiß White	3 x 6 m	Einsetzbar bei Schüco LivIng Can be used with Schüco LivIng

Flügelrahmen 82/83 Klebeflügel ■ Vent frame 82/83 for adhesive vent
19434...

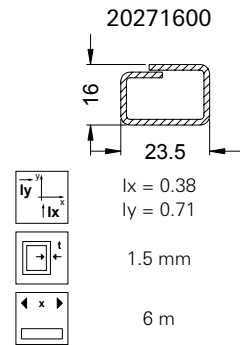
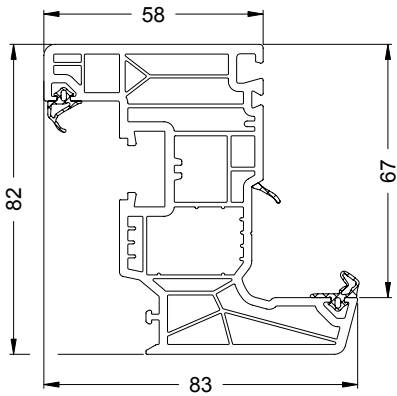

Art.-Nr. Art. No.	Abbildung Illustration	Benennung Description			
25254600		Reparaturdichtung: Anschlag- und Glasanlagendichtung Repair gasket: rebate gasket and glazing rebate gasket	schwarz Black	100 m*	EPDM-Dichtung, polymerisiert, nicht schweißbar EPDM gasket, polymerised, cannot be welded
25254500			silbergrau Silver grey		
25255000		Reparaturdichtung: Flügelanschlagdichtung Repair gasket: vent rebate gasket	schwarz Black	100 m*	EPDM-Dichtung, polymerisiert, nicht schweißbar EPDM gasket, polymerised, cannot be welded
25254900			silbergrau Silver grey		
25096600		Klotzbrücke Glazing bridge	dunkelblau Dark blue	250 Stk.	Tragklotz für 0 mm Falztiefe Support block for 0 mm rebate depth
28653500		Distanzstück 11 mm Spacer 11 mm	gelb Yellow	20 Stk.	—
28645400		Distanzstück 12 mm Spacer 12 mm	grün Green	100 Stk.	—
28645500		Distanzstück 13 mm Spacer 13 mm	rot Red	20 Stk.	—

Hinweise:
Baubare Größen beachten!

Empfohlene Primer und Klebstoffe siehe
Kapitel Verglasung (Additive Klebetechnik).

Verarbeitungshinweise sind zu beachten!

Note:
Note the size options.

For recommended primer and adhesives, see
the „Glazing“ chapter (Additive adhesive
technology).

Follow the fabrication instructions.

Flügelrahmen 82/110 ■ Vent frame 82/110
19432...

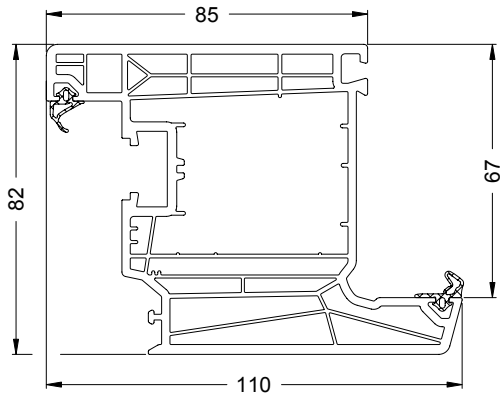

	20273900	20274300	20274200
	lx = 7.49 ly = 6.78	lx = 8.14 ly = 8.88	lx = 8.3 ly = 8.3
	2 mm	2 mm	2.5 mm
	6 m	6 m	6 m

Art.-Nr. Art. No.	Abbildung Illustration	Benennung Description			
25254600		Reparaturdichtung: Anschlag- und Glasanlagedichtung Repair gasket: rebate gasket and glazing rebate gasket	schwarz Black	100 m*	EPDM-Dichtung, polymerisiert, nicht schweißbar EPDM gasket, polymerised, cannot be welded
25254500			silbergrau Silver grey		
25255000		Reparaturdichtung: Flügelanschlagdichtung Repair gasket: vent rebate gasket	schwarz Black	100 m*	EPDM-Dichtung, polymerisiert, nicht schweißbar EPDM gasket, polymerised, cannot be welded
25254900			silbergrau Silver grey		
25094900		Klotzbrücke Glazing bridge	braun Brown	250 Stk.	Tragklotz für 3 mm Falztiefe Support block for 3 mm rebate depth
25094800		Klotzbrücke Glazing bridge	violett Violet	250 Stk.	Distanzklotz für 3 mm Falztiefe Spacer block for 3 mm rebate depth
28617400		Eckverbinder, schweißbar Weldable corner cleat	—	8 Stk.	Einsatz mit Verstärkung: 20274200 For use with reinforcement: 20274200
25264700		Dämmfalzeinleger 67 LivIng LivIng insulating rebate insert 67	—	80 m	—
19640000		Falzeinlage 67/3 Rebate insert 67/3	weiß White	3 x 6 m	Einsetzbar bei Schüco LivIng Can be used with Schüco LivIng

Flügelrahmen 82/110 nach außen öffnend ■ Vent frame 82/110, outward-opening
19452...

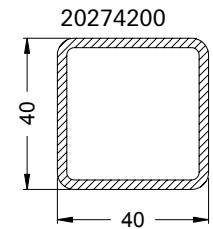
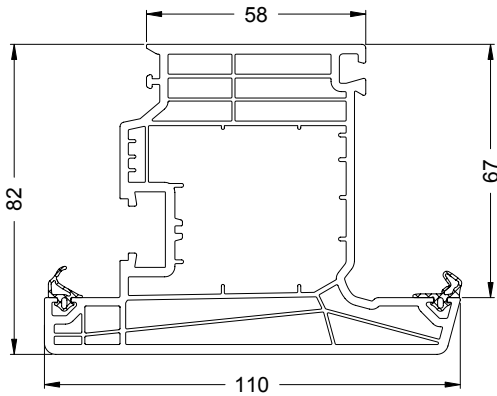

lx = 8.3
ly = 8.3



2.5 mm



6 m

Art.-Nr. Art. No.	Abbildung Illustration	Benennung Description			
25254600		Reparaturdichtung: Anschlag- und Glasanlagendichtung Repair gasket: rebate gasket and glazing rebate gasket	schwarz Black	100 m*	EPDM-Dichtung, polymerisiert, nicht schweißbar EPDM gasket, polymerised, cannot be welded
25254500			silbergrau Silver grey		
25255000		Reparaturdichtung: Flügelanschlagdichtung Repair gasket: vent rebate gasket	schwarz Black	100 m*	EPDM-Dichtung, polymerisiert, nicht schweißbar EPDM gasket, polymerised, cannot be welded
25254900			silbergrau Silver grey		
25061800		Anschlagdichtung Rebate gasket	silbergrau Silver grey	50 m*	Anschlagdichtung für oberen Teil des Flügelrahmens, für auswärts öffnende Türen Rebate gasket for upper part of the leaf frame, for outward-opening doors
25061700			schwarz Black		
25094900		Klotzbrücke Glazing bridge	braun Brown	250 Stk.	Tragklotz für 3 mm Falztiefe Support block for 3 mm rebate depth
25094800		Klotzbrücke Glazing bridge	violett Violet	250 Stk.	Distanzklotz für 3 mm Falztiefe Spacer block for 3 mm rebate depth
28617400		Eckverbinder, schweißbar Weldable corner cleat	—	8 Stk.	—
25264700		Dämmfalzeinleger 67 LivIng LivIng insulating rebate insert 67	—	80 m	—
19640000		Falzeinlage 67/3 Rebate insert 67/3	weiß White	3 x 6 m	Einsetzbar bei Schüco LivIng Can be used with Schüco LivIng

Flügelrahmen 82/125 ■ Vent frame 82/125

19433... Lieferlänge: 6,5 m ■ Stock length: 6.5 m

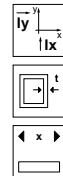
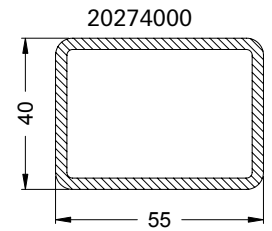
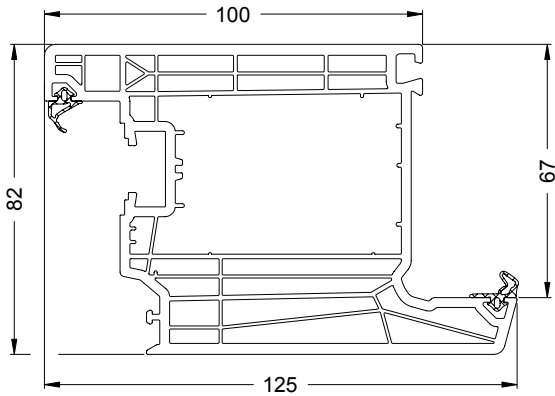

lx = 21.02
ly = 12.71

3 mm

6 m

Art.-Nr. Art. No.	Abbildung Illustration	Benennung Description			
25254600		Reparaturdichtung: Anschlag- und Glasanlagedichtung Repair gasket: rebate gasket and glazing rebate gasket	schwarz Black	100 m*	EPDM-Dichtung, polymerisiert, nicht schweißbar EPDM gasket, polymerised, cannot be welded
25254500			silbergrau Silver grey		
25255000		Reparaturdichtung: Flügelanschlagdichtung Repair gasket: vent rebate gasket	schwarz Black	100 m*	EPDM-Dichtung, polymerisiert, nicht schweißbar EPDM gasket, polymerised, cannot be welded
25254900			silbergrau Silver grey		
25094900		Klotzbrücke Glazing bridge	braun Brown	250 Stk.	Tragklotz für 3 mm Falztiefe Support block for 3 mm rebate depth
25094800		Klotzbrücke Glazing bridge	violett Violet	250 Stk.	Distanzklotz für 3 mm Falztiefe Spacer block for 3 mm rebate depth
25237500		Eckverbinder, schweißbar Weldable corner cleat	—	8 Stk.	—
25237600		Eckverbinder, schweißbar Weldable corner cleat	—	128 Stk.	—
25264700		Dämmfalzeinleger 67 LivIng LivIng insulating rebate insert 67	—	80 m	—
19640000		Falzeinlage 67/3 Rebate insert 67/3	weiß White	3 x 6 m	Einsetzbar bei Schüco LivIng Can be used with Schüco LivIng

Flügelrahmen 82/125 nach außen öffnend ■ Vent frame 82/125, outward-opening

19453... Lieferlänge: 6,5 m ■ Stock length: 6.5 m

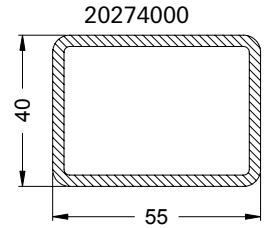
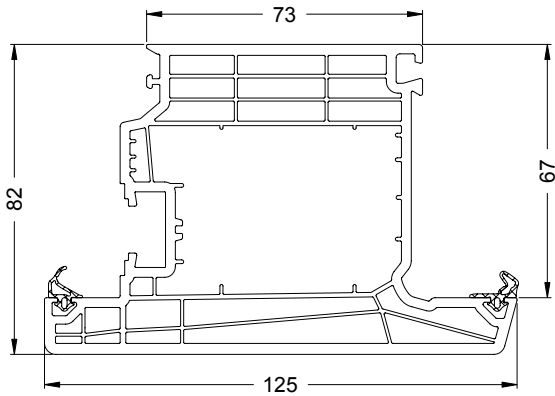

lx = 21.02
ly = 12.71



3 mm



6 m

Art.-Nr. Art. No.	Abbildung Illustration	Benennung Description			
25254600		Reparaturdichtung: Anschlag- und Glasanlagedichtung Repair gasket: rebate gasket and glazing rebate gasket	schwarz Black	100 m*	EPDM-Dichtung, polymerisiert, nicht schweißbar EPDM gasket, polymerised, cannot be welded
25254500			silbergrau Silver grey		
25255000		Reparaturdichtung: Flügelanschlagdichtung Repair gasket: vent rebate gasket	schwarz Black	100 m*	EPDM-Dichtung, polymerisiert, nicht schweißbar EPDM gasket, polymerised, cannot be welded
25254900			silbergrau Silver grey		
25061800		Anschlagdichtung Rebate gasket	silbergrau Silver grey	50 m*	Anschlagdichtung für oberen Teil des Flügelrahmens, für auswärts öffnende Türen Rebate gasket for upper part of the leaf frame, for outward-opening doors
25061700			schwarz Black		
25094900		Klotzbrücke Glazing bridge	braun Brown	250 Stk.	Tragklotz für 3 mm Falztiefe Support block for 3 mm rebate depth
25094800		Klotzbrücke Glazing bridge	violett Violet	250 Stk.	Distanzklotz für 3 mm Falztiefe Spacer block for 3 mm rebate depth
25237500		Eckverbinder, schweißbar Weldable corner cleat	—	8 Stk.	—
25237600			—	128 Stk.	—
25264700		Dämmfalzeinleger 67 LivIng LivIng insulating rebate insert 67	—	80 m	—
19640000		Falzeinlage 67/3 Rebate insert 67/3	weiß White	3 x 6 m	Einsetzbar bei Schüco LivIng Can be used with Schüco LivIng

Flügelrahmen 82/103 ■ Vent frame 82/103

19435... Lieferlänge: 6,5 m ■ Stock length: 6.5 m

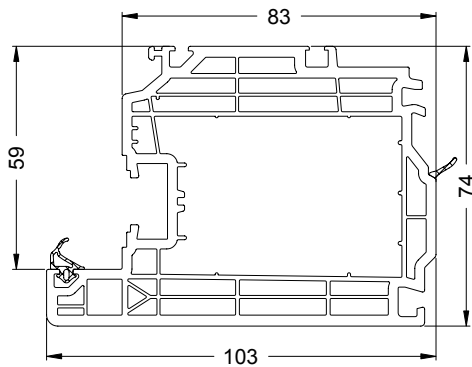

Verfügbar ab 4. Quartal
Available from the 4th quarter

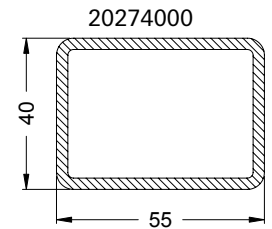

lx = 21.02
ly = 12.71



3 mm





6 m

Art.-Nr. Art. No.	Abbildung Illustration	Benennung Description			
25255000		Reparaturdichtung: Flügelanschlagdichtung Repair gasket: vent rebate gasket	schwarz Black	100 m*	EPDM-Dichtung, polymerisiert, nicht schweißbar EPDM gasket, polymerised, cannot be welded
25254900			silbergrau Silver grey		
25237500		Eckverbinder, schweißbar Weldable corner cleat	—	8 Stk.	—
25237600			—	128 Stk.	—
14705500		Alu-Befestigungswinkel 69/12 Aluminium fixing bracket 69/12	roh mill finish	6 m	—
14705800		Klemmwinkel 18/23 Clamping angle 18/23	schwarz Black	6 m	—

Glazabzugsmaßtabellen Glass deduction tables

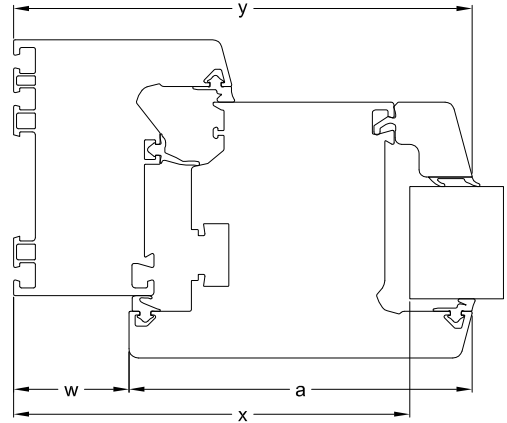
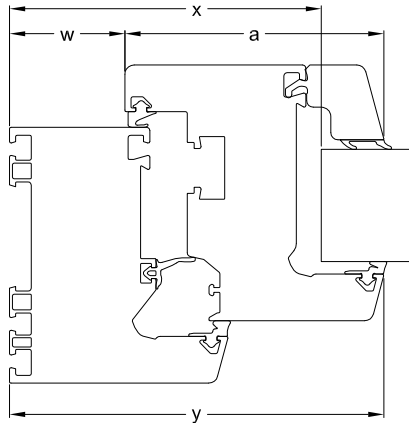
Flügelrahmen ■ Vent frame



Blendrahmen 70 mm Outer frames 70 mm					
Gesamtansichtsmaß (a) Total face width (a)		73 mm	83 mm	110 mm	125 mm
Flügelabzugsmaß (w) Vent deduction (w)		37	37	37	37
Glasabzugsmaß (x) Glass deduction (x)		90	100	127	142
Ansichtsbreite (y) Face width (y)		110	120	147	162

Blendrahmen 80 mm Outer frames 80 mm					
Gesamtansichtsmaß (a) Total face width (a)		73 mm	83 mm	110 mm	125 mm
Flügelabzugsmaß (w) Vent deduction (w)		47	47	47	47
Glasabzugsmaß (x) Glass deduction (x)		100	110	137	152
Ansichtsbreite (y) Face width (y)		120	130	157	172

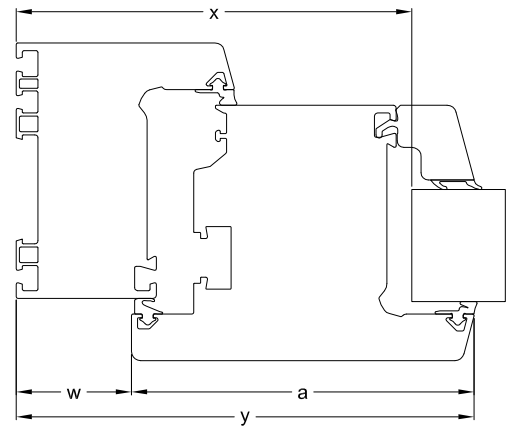
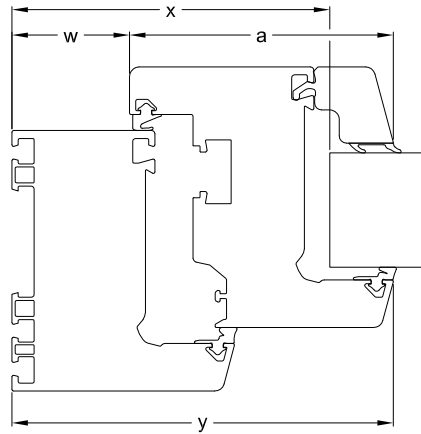

Blendrahmen 90 mm Outer frames 90 mm					
Gesamtansichtsmaß (a) Total face width (a)		73 mm	83 mm	110 mm	125 mm
Flügelabzugsmaß (w) Vent deduction (w)		57	57	57	57
Glasabzugsmaß (x) Glass deduction (x)		110	120	147	162
Ansichtsbreite (y) Face width (y)		130	140	167	182

Blendrahmen 100 mm Outer frames 100 mm					
Gesamtansichtsmaß (a) Total face width (a)		73 mm	83 mm	110 mm	125 mm
Flügelabzugsmaß (w) Vent deduction (w)		67	67	67	67
Glasabzugsmaß (x) Glass deduction (x)		120	130	157	172
Ansichtsbreite (y) Face width (y)		140	150	177	192

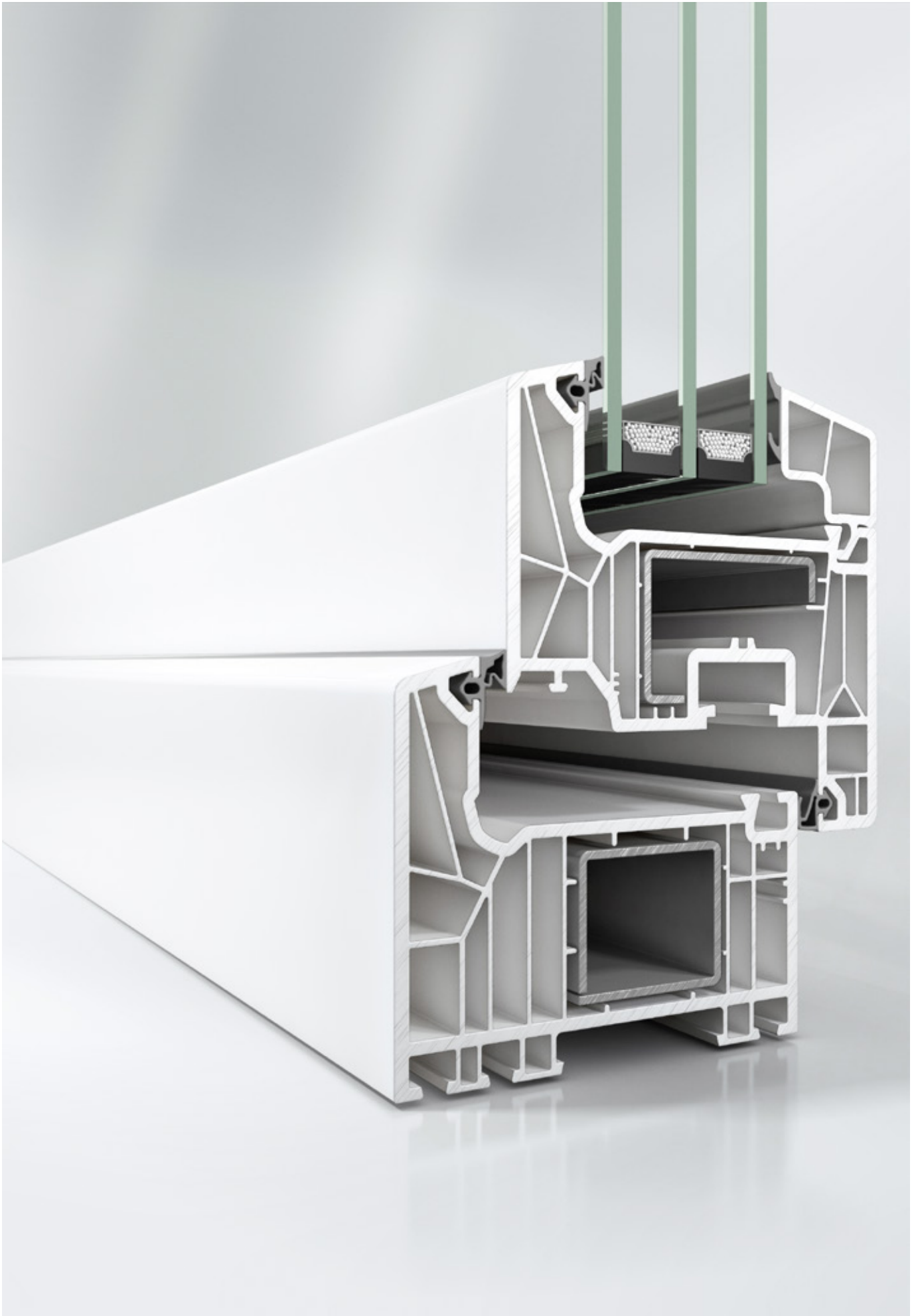

T-Profile und Sprossen

T-profiles and sash bars

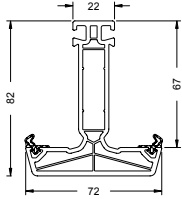
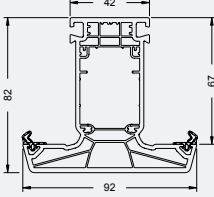
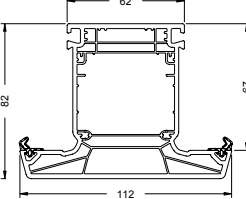
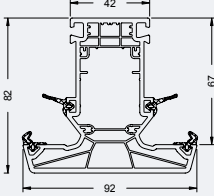
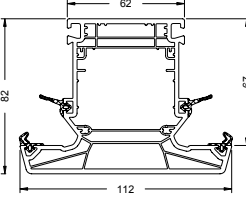
Art.-Nr. Art. No.	Abbildung Illustration	Benennung Description		
19460...		Flügelprosse 82/72 Vent sash bar 82/72	AS MD	50
19461...		T-Profil 82/92 AS T-profile 82/92 AS	AS MD	51
19462...		T-Profil 82/112 AS T-profile 82/112 AS	AS	52
19465...		T-Profil 82/92 MD T-profile 82/92 MD	MD	53
19466...		T-Profil 82/112 MD T-profile 82/112 MD	MD	54

Flügelprosse 82/72 ■ Vent sash bar 82/72
19460...

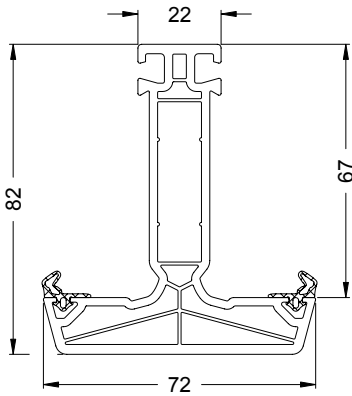

20272800

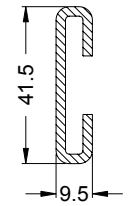

lx = 3.38
ly = 0.2



2.5 mm



6 m

Art.-Nr. Art. No.	Abbildung Illustration	Benennung Description			
25254600		Reparaturdichtung: Anschlag- und Glasanlagendichtung Repair gasket: rebate gasket and glazing rebate gasket	schwarz Black	100 m*	EPDM-Dichtung, polymerisiert, nicht schweißbar EPDM gasket, polymerised, cannot be welded
25254500			silbergrau Silver grey		
25094900		Klotzbrücke Glazing bridge	braun Brown	250 Stk.	Tragklotz für 3 mm Falztiefe Support block for 3 mm rebate depth
25094800		Klotzbrücke Glazing bridge	violett Violet	250 Stk.	Distanzklotz für 3 mm Falztiefe Spacer block for 3 mm rebate depth
25094500		Sprossenverbinder Sash bar connector	Silberfarbig Silver	20 Stk.	Sprossenverbinder für 3 mm Falztiefe Sash bar connectors for 0 mm rebate depth
25094600		KS-Verbinder Plastic connector	grau Grey	20 Stk.	—

T-Profil 82/92 AS ■ T-profile 82/92 AS
19461...

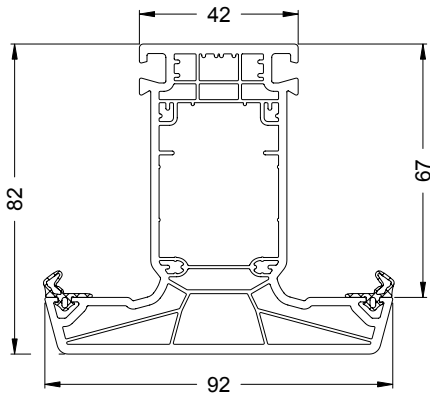

	20272900	20273000	20273100	20271700	20271800
lx =	3.73	5.65	6.6	2.01	2.94
ly =	2.34	3.13	3.66	1.6	2.33
	1.5 mm	2 mm	2.5 mm	1.5 mm	2.5 mm
	6 m	6 m	6 m	6 m	6 m

Art.-Nr. Art. No.	Abbildung Illustration	Benennung Description			
25254600		Reparaturdichtung: Anschlag- und Glasanlagendichtung	schwarz	100 m*	EPDM-Dichtung, polymerisiert, nicht schweißbar
25254500		Repair gasket: rebate gasket and glazing rebate gasket	silbergrau		
25094900		Klotzbrücke Glazing bridge	braun	250 Stk.	Tragklotz für 3 mm Falztiefe Support block for 3 mm rebate depth
25094800		Klotzbrücke Glazing bridge	violett	250 Stk.	Distanzklotz für 3 mm Falztiefe Spacer block for 3 mm rebate depth
25090700		Rahmenverbinder	schwarz	20 Stk.	Rahmenverbinder für 3 mm Falztiefe
25090500		Frame connector	Silberfarbig		
25090800		Falzverbinder	schwarz	20 Stk.	Falzverbinder für 3 mm Falztiefe
25090600		Rebate connector	Silberfarbig		
25090900		KS-Verbinder Plastic connector	grau	20 Stk.	—

T-Profil 82/112 AS ■ T-profile 82/112 AS
19462...

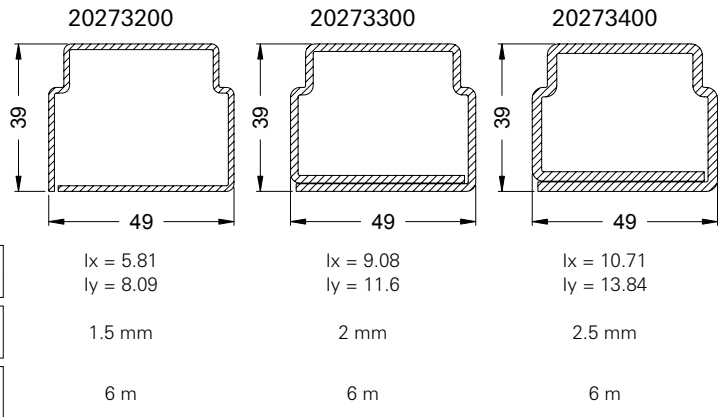
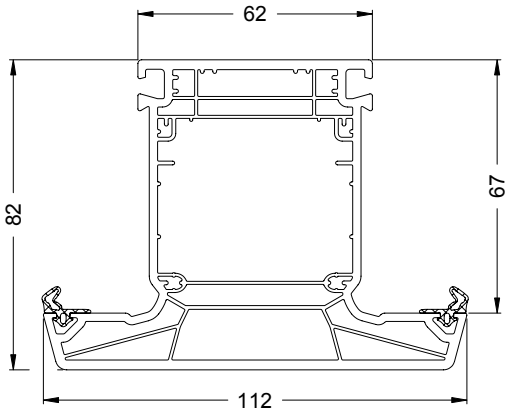

Art.-Nr. Art. No.	Abbildung Illustration	Benennung Description			
25254600		Reparaturdichtung: Anschlag- und Glasanlagedichtung	schwarz	100 m*	EPDM-Dichtung, polymerisiert, nicht schweißbar
25254500		Repair gasket: rebate gasket and glazing rebate gasket	silbergrau		
25094900		Klotzbrücke Glazing bridge	braun	250 Stk.	Tragklotz für 3 mm Falztiefe Support block for 3 mm rebate depth
25094800		Klotzbrücke Glazing bridge	violett	250 Stk.	Distanzklotz für 3 mm Falztiefe Spacer block for 3 mm rebate depth
25091200		Rahmenverbinder	schwarz	20 Stk.	Rahmenverbinder für 3 mm Falztiefe
25091000		Frame connector	Silberfarbig		
25091300		Falzverbinder	schwarz	20 Stk.	Falzverbinder für 3 mm Falztiefe
25091100		Rebate connector	Silberfarbig		
25091400		KS-Verbinder Plastic connector	grau	20 Stk.	—

T-Profil 82/92 MD ■ T-profile 82/92 MD
19465...

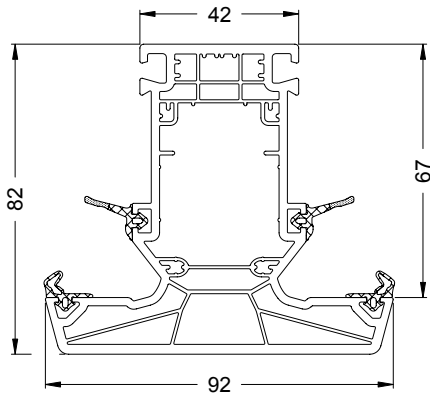

	20272900	20273000	20273100	20271700	20271800
$l_x =$	3.73	5.65	6.6	2.01	2.94
$l_y =$	2.34	3.13	3.66	1.6	2.33
$t =$	1.5 mm	2 mm	2.5 mm	1.5 mm	2.5 mm
$x =$	6 m	6 m	6 m	6 m	6 m

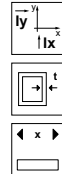

Art.-Nr. Art. No.	Abbildung Illustration	Benennung Description			
25254600		Reparaturdichtung: Anschlag- und Glasanlagendichtung Repair gasket: rebate gasket and glazing rebate gasket	schwarz Black	100 m*	EPDM-Dichtung, polymerisiert, nicht schweißbar EPDM gasket, polymerised, cannot be welded
25254500			silbergrau Silver grey		
25254000		Reparaturdichtung: Mitteldichtung Repair gasket: centre gasket	schwarz Black	100 m*	EPDM-Dichtung, polymerisiert, nicht schweißbar EPDM gasket, polymerised, cannot be welded
25253900			silbergrau Silver grey		
25094700		Klotzbrücke Glazing bridge	orange Orange	250 Stk.	Trag- und Distanzklotz für 3 mm Falztiefe Support and spacer block for 3 mm rebate depth
25092000		Rahmenverbinder Frame connector	schwarz Black	20 Stk.	Rahmenverbinder für 3 mm Falztiefe Frame connector for 3 mm rebate depth
25091700			Silberfarbig Silver		
25091500			Silberfarbig Silver		
25092100		Falzverbinder Rebate connector	schwarz Black	20 Stk.	Falzverbinder für 3 mm Falztiefe Rebate connector for 3 mm rebate depth
25091900			Silberfarbig Silver		
25091800			Silberfarbig Silver		
25088700		Dichtblock Sealing block	schwarz Black	20 Stk.	—
25088600			silbergrau Silver grey		

T-Profil 82/112 MD ■ T-profile 82/112 MD
19466...

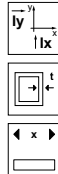
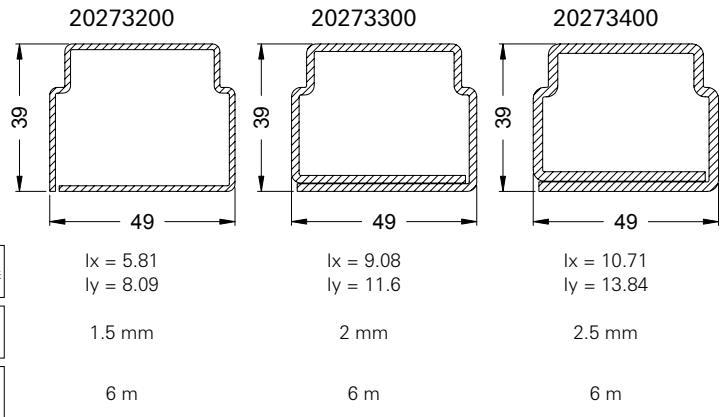
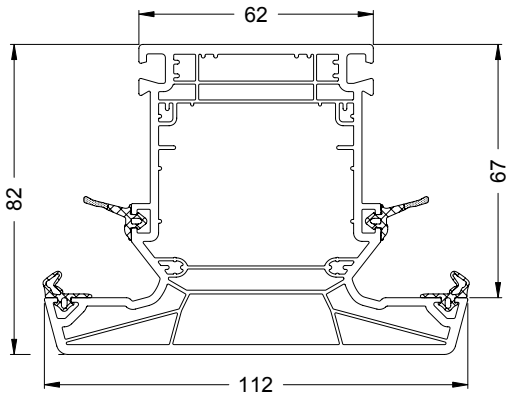

Profile
Profiles

Art.-Nr. Art. No.	Abbildung Illustration	Benennung Description			
25254000		Reparaturdichtung: Mitteldichtung Repair gasket: centre gasket	schwarz Black	100 m*	EPDM-Dichtung, polymerisiert, nicht schweißbar EPDM gasket, polymerised, cannot be welded
25253900			silbergrau Silver grey		
25254600		Reparaturdichtung: Anschlag- und Glasanlagendichtung Repair gasket: rebate gasket and glazing rebate gasket	schwarz Black	100 m*	EPDM-Dichtung, polymerisiert, nicht schweißbar EPDM gasket, polymerised, cannot be welded
25254500			silbergrau Silver grey		
25094700		Klotzbrücke Glazing bridge	orange Orange	250 Stk.	Trag- und Distanzklotz für 3 mm Falztiefe Support and spacer block for 3 mm rebate depth
25092700		Rahmenverbinder Frame connector	schwarz Black	20 Stk.	Rahmenverbinder für 3 mm Falztiefe Frame connector for 3 mm rebate depth
25092400			Silberfarbig Silver		
25092300			Silberfarbig Silver		
25093200		Falzverbinder Rebate connector	schwarz Black	20 Stk.	Falzverbinder für 3 mm Falztiefe Rebate connector for 3 mm rebate depth
25092600			Silberfarbig Silver		
25092500			Silberfarbig Silver		
25093300		Dichtblock Sealing block	schwarz Black	20 Stk.	—
25092200			silbergrau Silver grey		

Glazabzugsmaßtabellen

Glass deduction tables

T-Profile und Sprossen ■ T-profiles and sash bars

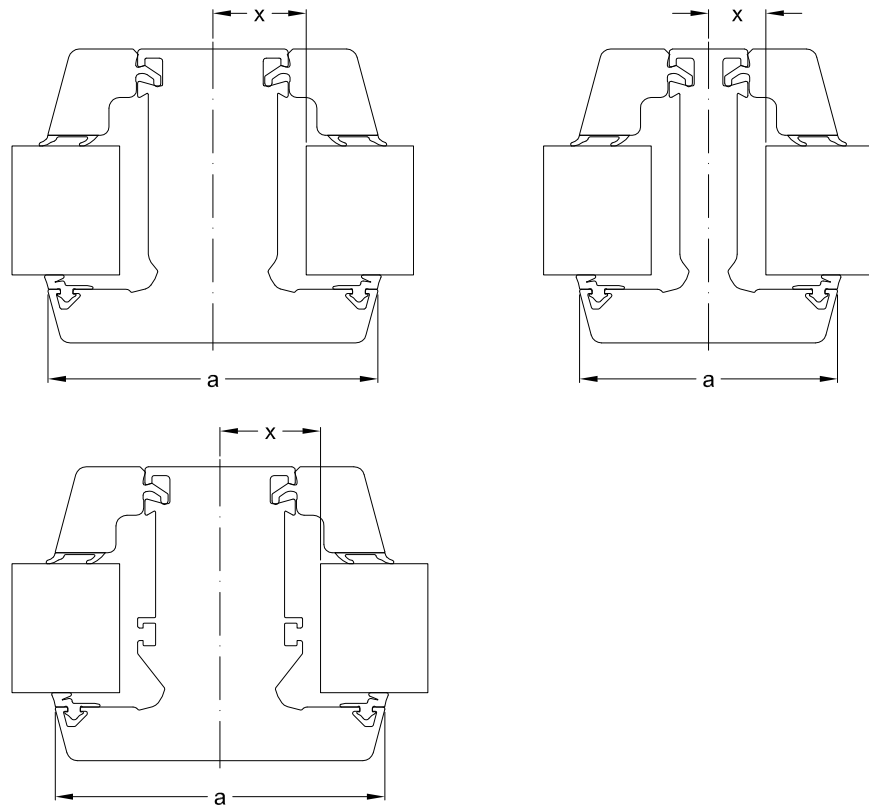

Gesamtansichtsmaß (a) Total face width (a)		72 mm	92 mm	112 mm
Glasabzugsmaß (x) Glass deduction (x)				
AS		16	26	36
MD		—	28	38

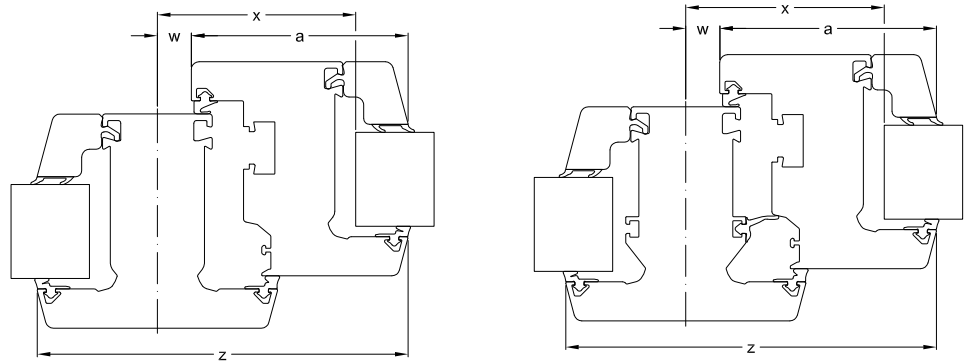



T-Profile und Sprossen 92 mm T-profiles and sash bars 92 mm

Gesamtansichtsmaß (a) Total face width (a)		—	73 mm	83 mm	110 mm	125 mm
Flügelabzugsmaß (w) Vent deduction (w)		—	13	13	13	13
Glasabzugsmaß (x) Glass deduction (x)	AS	26	66	76	103	118
	MD	28				
Ansichtsbreite (z) Face width (z)		92	132	142	169	184

T-Profile und Sprossen 112 mm T-profiles and sash bars 112 mm

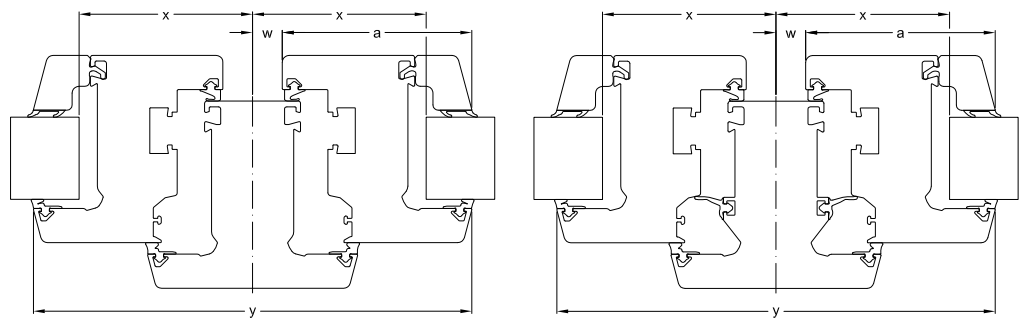
Gesamtansichtsmaß (a) Total face width (a)		—	73 mm	83 mm	110 mm	125 mm
Flügelabzugsmaß (w) Vent deduction (w)		—	23	23	23	23
Glasabzugsmaß (x) Glass deduction (x)	AS	36	76	86	113	128
	MD	38				
Ansichtsbreite (z) Face width (z)		112	152	162	189	204



T-Profil und Sprossen 92 mm T-profiles and sash bars 92 mm						
Gesamtansichtsmaß (a) Total face width (a)		—	73 mm	83 mm	110 mm	125 mm
Flügelabzugsmaß (w) Vent deduction (w)		—	13	13	13	13
Glasabzugsmaß (x) Glass deduction (x)	AS MD	26 28	66 76	76 86	103 113	118 128
Ansichtsbreite (y) Face width (y)		—	172	192	246	276

T-Profil und Sprossen 112 mm T-profiles and sash bars 112 mm						
Gesamtansichtsmaß (a) Total face width (a)		—	73 mm	83 mm	110 mm	125 mm
Flügelabzugsmaß (w) Vent deduction (w)		—	23	23	23	23
Glasabzugsmaß (x) Glass deduction (x)	AS MD	36 38	76 86	86 96	113 123	128 138
Ansichtsbreite (y) Face width (y)		—	192	212	266	296



Stulpprofile

Double-vent profiles

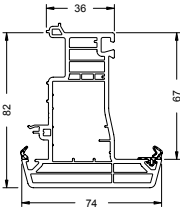
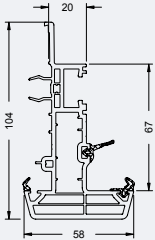
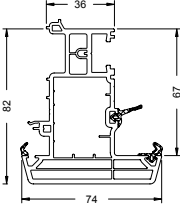
Art.-Nr. Art. No.	Abbildung Illustration	Benennung Description		
19473...		Stulpprofil 74 AS Double-vent profile 74 AS	AS	60
19471...		Stulpprofil 58 MD Double-vent profile 58 MD	AS MD	61
19472...		Stulpprofil 74 MD Double-vent profile 74 MD	AS MD	62

Stulpprofil 74 AS ■ Double-vent profile 74 AS
19473...

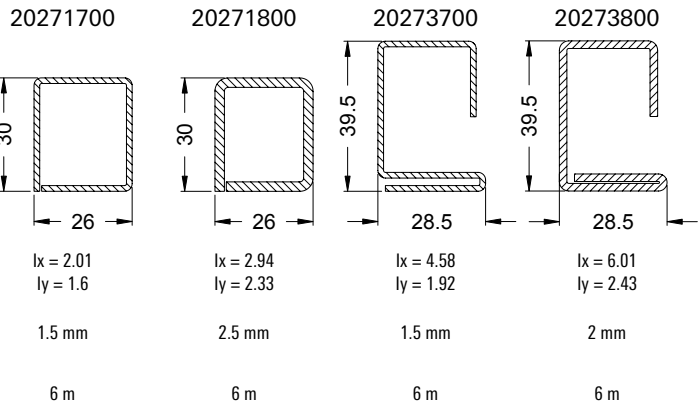
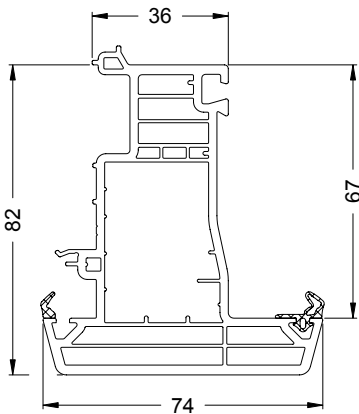

Art.-Nr. Art. No.	Abbildung Illustration	Benennung Description			
25254600		Reparaturdichtung: Anschlag- und Glaseinlagerung Repair gasket: rebate gasket and glazing rebate gasket	schwarz Black	100 m*	EPDM-Dichtung, polymerisiert, nicht schweißbar EPDM gasket, polymerised, cannot be welded
25254500			silbergrau Silver grey		
25235500		Stulpendstück (Grundkörper) Double-vent end piece (base profile)	weiß White	10 P.	—
25235600			schwarz Black		
25235700			cremeweiß Cream white		
25235900			karamell Caramel		
25259200			dunkelgrau Dark grey		
25096000			weiß White		
25096100		Stulpendstück (Außenteil 15°) Double-vent end piece (outside section 15°)	schwarz Black	10 P.	—
25096200			cremeweiß Cream white		
25096400			karamell Caramel		
25258500			dunkelgrau Dark grey		
25098200		Stulpendstück (Außenteil Schwelle) Double-vent end piece (outside section for threshold)	weiß White	5 Stk.	rechts Right
25098300			links Left		
25098400			rechts Right		
25098500			links Left		
25099100			rechts Right		
25099300			links Left		
25098600			rechts Right		
25098700			links Left		
25258600			rechts Right		
25258700			links Left		

Stulpprofil 58 MD ■ Double-vent profile 58 MD
19471...

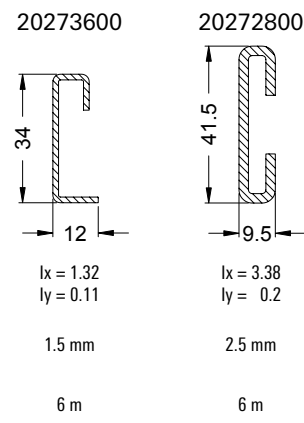
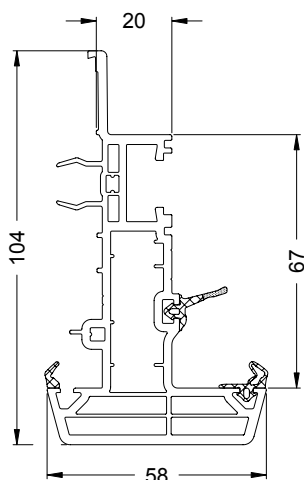

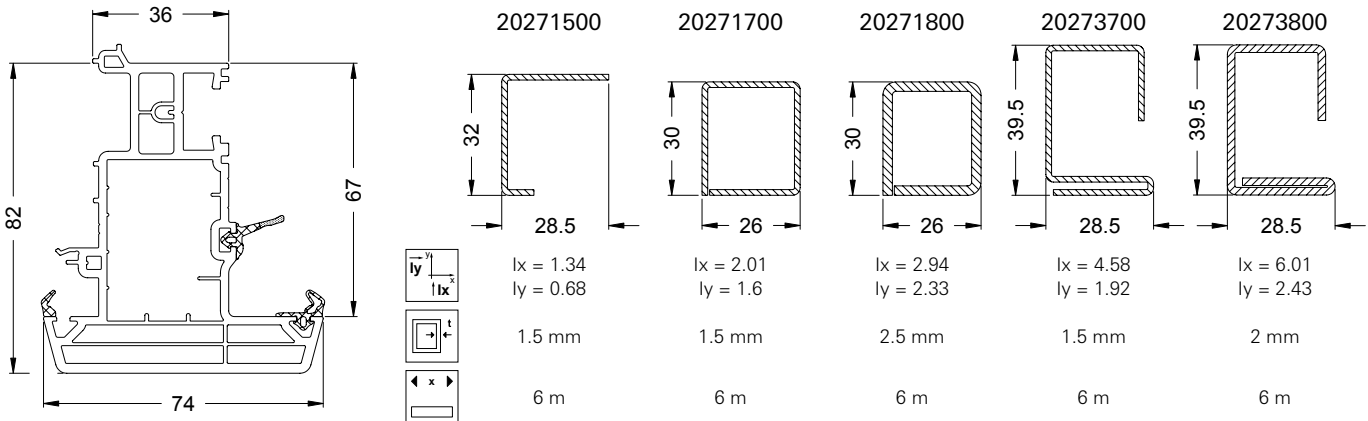

Art.-Nr. Art. No.	Abbildung Illustration	Benennung Description			
25254000		Reparaturdichtung: Mitteldichtung Repair gasket: centre gasket	schwarz Black	100 m*	EPDM-Dichtung, polymerisiert, nicht schweißbar EPDM gasket, polymerised, cannot be welded
25253900		silbergrau Silver grey			
25254600		Reparaturdichtung: Anschlag- und Glasanlagendichtung Repair gasket: rebate gasket and glazing rebate gasket	schwarz Black	100 m*	EPDM-Dichtung, polymerisiert, nicht schweißbar EPDM gasket, polymerised, cannot be welded
25254500		silbergrau Silver grey			
25096500		Stulpendstück, einteilig Double-vent end piece, one-piece	weiß White	100 P.	—
25096700		schwarz Black			
25096800		Stulpendstück (Grundkörper) Double-vent end piece (base profile)	weiß White	10 P.	—
25096900			weiß White		
25097000			schwarz Black		
25097200			karamell Caramel		
25258800			dunkelgrau Dark grey		
25097300		Stulpendstück (Außenteil 15°) Double-vent end piece (outside section 15°)	weiß White	10 P.	—
25097400			schwarz Black		
25097600			karamell Caramel		
25258900			dunkelgrau Dark grey		
25236500		Stulpendstück (Außenteil Schwelle) Double-vent end piece (outside section for threshold)	weiß White	5 Stk.	rechts Right
25236600			links Left		
25236700			rechts Right		
25236800			links Left		
25236900			rechts Right		
25237000			links Left		
25259000			rechts Right		
25259100			links Left		
			dunkelgrau Dark grey		

Stulpprofil 74 MD ■ Double-vent profile 74 MD
19472...

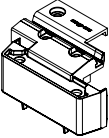

Art.-Nr. Art. No.	Abbildung Illustration	Benennung Description			
25254000		Reparaturdichtung: Mitteldichtung Repair gasket: centre gasket	schwarz Black	100 m*	EPDM-Dichtung, polymerisiert, nicht schweißbar EPDM gasket, polymerised, cannot be welded
25253900			silbergrau Silver grey		
25254600		Reparaturdichtung: Anschlag- und Glasanlagedichtung Repair gasket: rebate gasket and glazing rebate gasket	schwarz Black	100 m*	EPDM-Dichtung, polymerisiert, nicht schweißbar EPDM gasket, polymerised, cannot be welded
25254500			silbergrau Silver grey		
25095000		Stulpendstück, einteilig Double-vent end piece, one-piece	weiß White	100 P.	-
25095200			schwarz Black		
25095300		Stulpendstück (Grundkörper) Double-vent end piece (base profile)	weiß White	10 P.	-
25095400			weiß White		
25095500			schwarz Black		
25095600			cremeweiß Cream white		
25095700			cremeweiß Cream white		
25095900			karamell Caramel		
25258400			dunkelgrau Dark grey		
25096000			weiß White		
25096100	schwarz Black	10 P.	-		
25096200	cremeweiß Cream white				
25096400	karamell Caramel				
25258500	dunkelgrau Dark grey				

Art.-Nr. Art. No.	Abbildung Illustration	Benennung Description			
25098200		Stulpendstück (Außenteil Schwelle) Double-vent end piece (outside section for threshold)	weiß White	5 Stk.	rechts Right
25098300					links Left
25098400			schwarz Black		rechts Right
25098500					links Left
25099100			cremeweiß Cream white		rechts Right
25099300					links Left
25098600			karamell Caramel		rechts Right
25098700					links Left
25258600			dunkelgrau Dark grey		rechts Right
25258700					links Left

Glasabzugsmaßtabellen

Glass deduction tables

Stulpprofile ■ Double-vent profiles

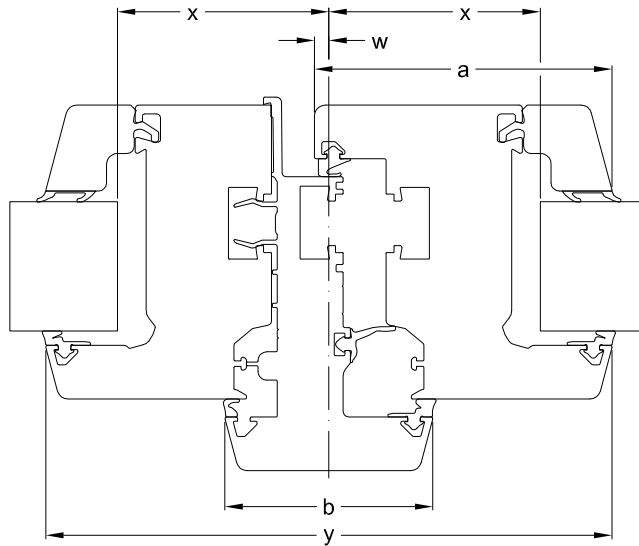

Stulpprofile b=58 mm Double-vent profiles b=58 mm					
Gesamtansichtsmaß (a) Total face width (a)		73 mm	83 mm	110 mm	125 mm
Flügelabzugsmaß (w) Vent deduction (w)		-4	-4	-4	-4
Glasabzugsmaß (x) Glass deduction (x)		49	59	86	101
Ansichtsbreite (y) Face width (y)		138	158	212	242

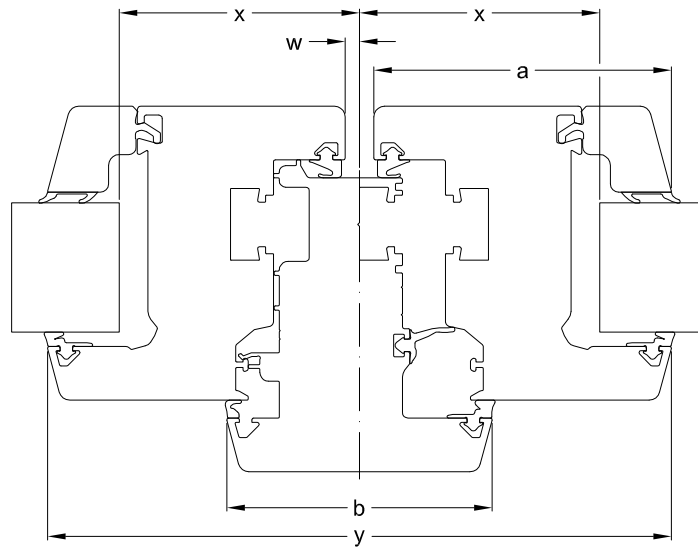

Stulpprofile b=74 mm Double-vent profiles b=74 mm					
Gesamtansichtsmaß (a) Total face width (a)		73 mm	83 mm	110 mm	125 mm
Flügelabzugsmaß (w) Vent deduction (w)		4	4	4	4
Glasabzugsmaß (x) Glass deduction (x)		57	67	94	109
Ansichtsbreite (y) Face width (y)		154	174	228	258

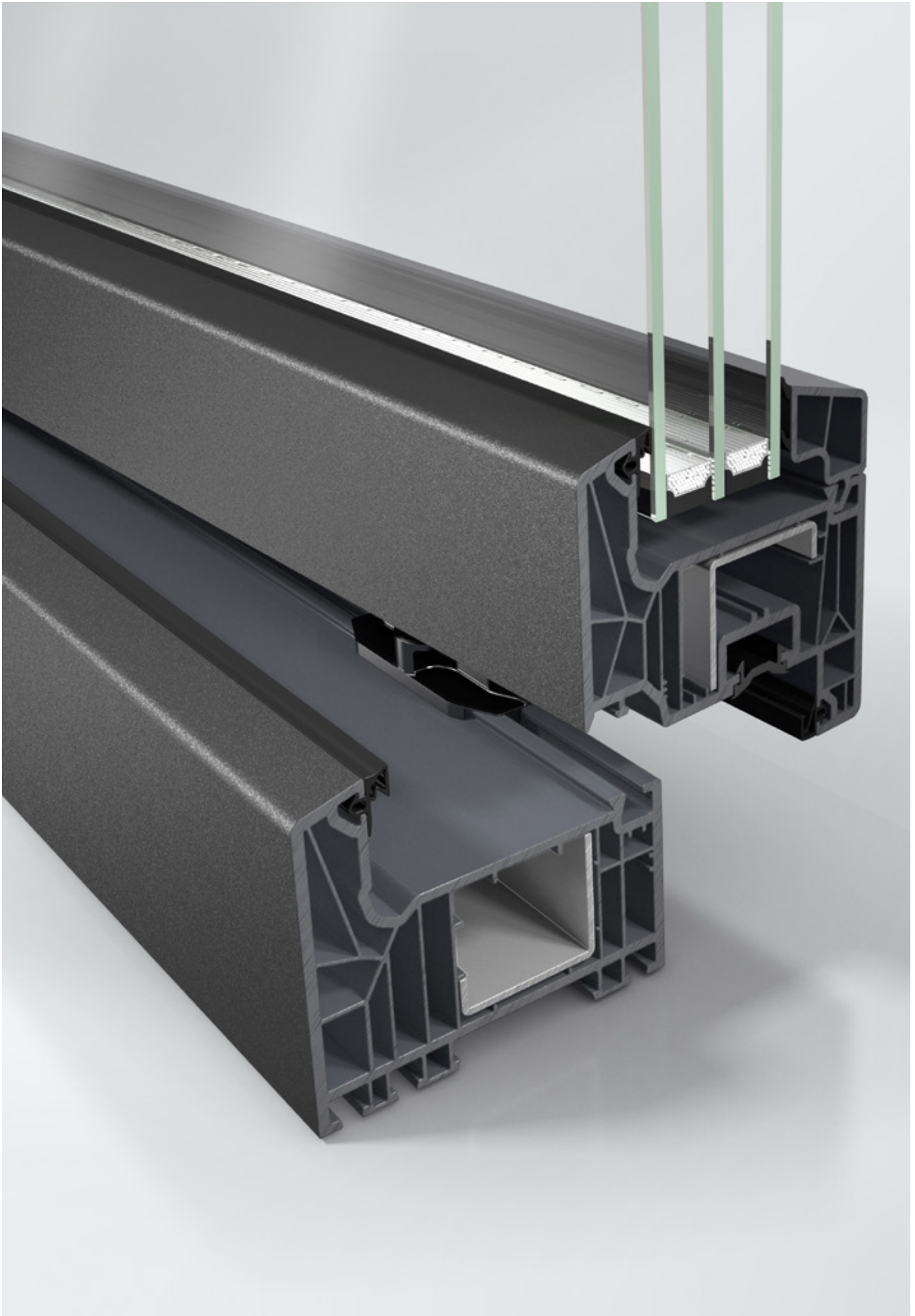









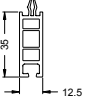
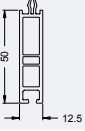

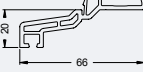
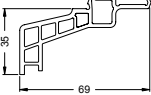

Zusatzprofile

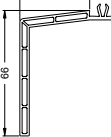
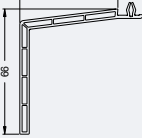
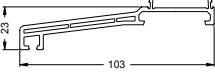
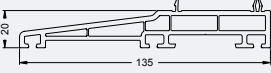
Supplementary profiles

Art.-Nr. Art. No.	Abbildung Illustration	Benennung Description	Schüco LivIng	
19256...		Blendrahmenverbreiterung 82/25 5K Outer frame extension 82/25 5K	AS/ MD	6,0 m
19257...		Blendrahmenverbreiterung 82/50 5K Outer frame extension 82/50 5K	AS/ MD	6,0 m
19258...		Blendrahmenverbreiterung 82/120 5K Outer frame extension 82/120 5K	AS/ MD	6,0 m
19841...		Blendrahmenverbreiterung 70/25 4K Outer frame extension 70/25 4K	AS/ MD	6,0 m
19842...		Blendrahmenverbreiterung 70/50 4K Outer frame extension 70/50 4K	AS/ MD	6,0 m
19843...		Blendrahmenverbreiterung 70/120 4K Outer frame extension 70/120 4K	AS/ MD	6,0 m
19229...		Basisprofil 70/40 4K Base profile 70/40 4K	AS/ MD	6,0 m
19227...		Basisprofil 70/120 4K Base profile 70/120 4K	AS/ MD	6,0 m

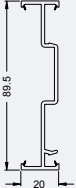
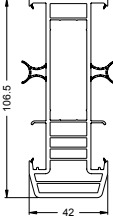
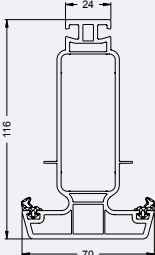

Art.-Nr. Art. No.	Abbildung Illustration	Benennung Description	Schüco LivIng	
18896170		Basisprofil 60/100 3K Base profile 60/100 3K	AS/ MD	6,0 m
19270...		Basisprofil 15/30 Base profile 15/30	AS/ MD	6,0 m
18033...		Basisprofil 20/30 2K Base profile 20/30 2K	AS/ MD	6,0 m
18441170		Basisprofil 31/30 3K (Recyclat) Base profile 31/30 3K (recycled material)	AS/ MD	6,0 m
18299...		Basisprofil 46/30 3K Base profile 46/30 3K	AS/ MD	6,0 m
18479000		Basisprofil 45/30 3K (Recyclat) Base profile 45/30 3K (recycled material)	AS/ MD	6,0 m
19197170		Basisprofil 60/30 5K (Recyclat) Base profile 60/30 5K (recycled material)	AS/ MD	6,0 m
18274...		Basisprofil 55/35 2K Base profile 55/35 2K	AS/ MD	6,0 m
18674...		Basis- und Transportschutzprofil (Recyclat) Base and transport protection profiles (recycled material)	AS/ MD	6,0 m
19213...		Anschlussprofil 12,5/25 Attachment profile 12.5/25	AS/ MD	6,0 m
19214...		Anschlussprofil 12,5/50 Attachment profile 12.5/50	AS/ MD	6,0 m
19228...		Anschlussprofil 12,5/55 Attachment profile 12.5/55	AS/ MD	6,0 m
18474...		Anschlussprofil 12,5/55 Attachment profile 12.5/55	AS/ MD	6,0 m
18404...		Anschlussprofil 12,5/55 Attachment profile 12.5/55	AS/ MD	6,0 m

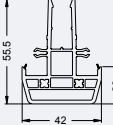
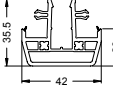
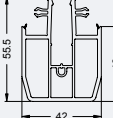
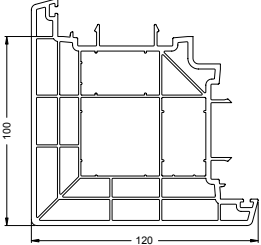
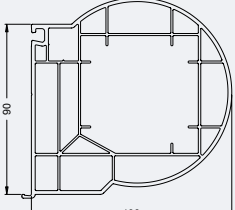
Art.-Nr. Art. No.	Abbildung Illustration	Benennung Description	Schüco LivIng	
18759...		Anschlussprofil 12,5/35 Attachment profile 12.5/35	AS/ MD	6,0 m
18769...		Anschlussprofil 12,5/50 Attachment profile 12.5/50	AS/ MD	6,0 m
18054000		Anschlussprofil 13,5/15 Attachment profile 13.5/15	AS/ MD	6,0 m
18839...		Anschlussprofil 15/20 Attachment profile 15/20	AS/ MD	6,0 m
19051...		Anschlussprofil 12,5/20 mit Dichtung Attachment profile 12.5/20 with gasket	AS/ MD	6,0 m
18439...		Fensterbankprofil 66/20 Window sill profile 66/20	AS/ MD	6,0 m
19295...		Fensterbankprofil 69/35 Window sill profile 69/35	AS/ MD	6,0 m
19833...		Fensterbankprofil 78,5/31 Window sill profile 78.5/31	AS/ MD	6,0 m
17788...		Fensterbankprofil 37/66 Window sill profile 37/66	AS/ MD	6,0 m
17607...		Fensterbankprofil 52/66 Window sill profile 52/66	AS/ MD	6,0 m
18273...		Fensterbankprofil 103/23 Window sill profile 103/23	AS/ MD	6,0 m
19019...		Fensterbankprofil 135/20 Window sill profile 135/20	AS/ MD	6,0 m
17112...		Fensterbankprofil 157/37 Window sill profile 157/37	AS/ MD	6,0 m
17609020		Passfeder 4/14 Spring pin 4/14	AS/ MD	6,0 m
18423...		Kopplungsprofil 15/17 Coupling profile 15/17	AS/ MD	6,0 m

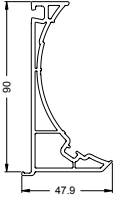
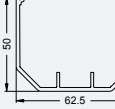
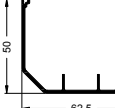
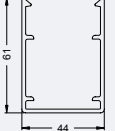
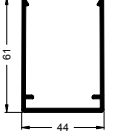
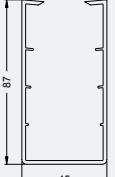
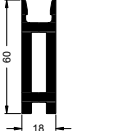
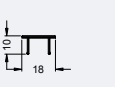
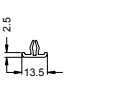
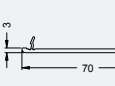
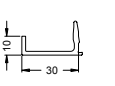
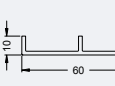
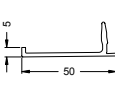
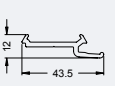
Art.-Nr. Art. No.	Abbildung Illustration	Benennung Description	Schüco LivIng	
19150...		Kopplungsprofil 89,5/20 Coupling profile 89.5/20	AS/ MD	6,0 m
19212...		Kopplungsprofil 106,5/42 7K Coupling profile 106.5/42 7K	AS/ MD	6,0 m
19190...		Statikpfosten 116/70 5K Structural mullion 116/70 5K	AS/ MD	6,0 m
19280...		Kopplungsprofil 15,5 Coupling profile 15.5	AS/ MD	6,0 m
19281...		Kopplungsprofil 42/20 Coupling profile 42/20	AS/ MD	6,0 m
19282...		Kopplungsprofil 42/20 Coupling profile 42/20	AS/ MD	6,0 m
19283...		Kopplungsprofil 42/40 Coupling profile 42/40	AS/ MD	6,0 m
18485...		Eckkopplung 90° 120 Corner coupling 90° 120	AS/ MD	6,0 m
19831...		Variable Eckkopplung 90/106 Variable corner coupling 90/106	AS/ MD	6,0 m

Art.-Nr. Art. No.	Abbildung Illustration	Benennung Description	Schüco LivIng	
19830...		Eckprofil 90/48 (variable Eckkopplung) Corner profile 90/48 (variable corner coupling)	AS/ MD	6,0 m
18438000		Statik-Abdeckprofil 50/62,5 Structural cover profile 50/62.5	AS/ MD	6,0 m
13221600 13221610 17026...		Alu-Statikabdeckprofil 50/62.5 Aluminium structural cover profile 50/62.5	AS/ MD	6,0 m
17206000		Statik-Abdeckprofil 61/44 Structural cover profile 61/44	AS/ MD	6,0 m
11056200 11056210 17025...		Alu-Statikabdeckprofil 61/44 Aluminium structural cover profile 61/44	AS/ MD	6,0 m
18752...		Statik-Abdeckprofil 87/45 Structural cover profile 87/45	AS/ MD	6,0 m
13297900 13297910		Alu-Statikprofil 60/18 Aluminium structural profile 60/18	AS/ MD	6,0 m
13298000 13298010		Alu-Abdeckprofil 10/18 Aluminium cover profile 10/18	AS/ MD	6,0 m
18008...		Nutabdeckprofil Groove cover profile	AS/ MD	6,0 m
18823...		Verkleidungsprofil 70 Cladding profile 70	AS/ MD	6,0 m
17613...		Wandanschlussprofil 30/10 Wall attachment profile 30/10	AS/ MD	6,0 m
17614...		Wandanschlussprofil 60/10 Wall attachment profile 60/10	AS/ MD	6,0 m
17818...		Wandanschlussprofil 50/5 Wall attachment profile 50/5	AS/ MD	6,0 m
17612...		Adapterprofil 43,5/12 Adapter profile 43.5/12	AS/ MD	6,0 m

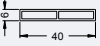
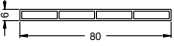
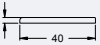
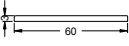
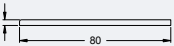
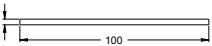
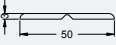
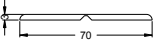
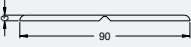
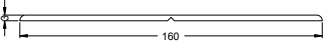
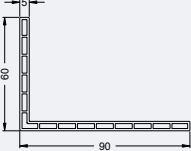
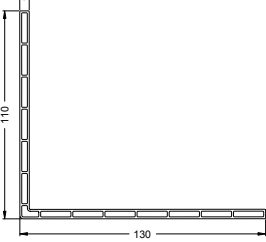

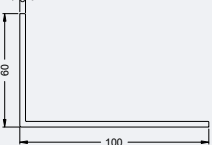



Art.-Nr. Art. No.	Abbildung Illustration	Benennung Description	Schüco LivIng	
13296900		Alu-Adapterprofil 47/12 (roh) Aluminium adapter profile 47/12 (mill finish)	AS/ MD	6,0 m
19045...		Verkleidungsprofil 6/30 Cladding profile 6/30	AS/ MD	6,0 m
11550800		Alu-Adapterprofil 51/10 (roh) Aluminium adapter profile 51/10 (mill finish)	AS/ MD	6,0 m
19001...		Abdeckprofil 10,5/60 Cover profile 10.5/60	AS/ MD	6,0 m
18792...		Verkleidungsprofil 15/75 Cladding profile 15/75	AS/ MD	6,0 m
18793...		Verkleidungsprofil 15/100 Cladding profile 15/100	AS/ MD	6,0 m
19029...		Verkleidungsprofil 10/90 Cladding profile 10/90	AS/ MD	6,0 m
19028...		Verkleidungsprofil 10/180 Cladding profile 10/180	AS/ MD	6,0 m
19047...		Verkleidungsprofil 10/250 Cladding profile 10/250	AS/ MD	6,0 m
18275...		Füllungsprofil 24/200 Infill profile 24/200	AS/ MD	6,0 m
19187...		Füllungsprofil 24/300 Infill profile 24/300	AS/ MD	6,0 m
18393...		Abdeckprofil 36/20 Cover profile 36/20	AS/ MD	6,0 m
17710...		Abdeckprofil 30/7.5, selbstklebend Cover profile 30/7.5, self-adhesive	AS/ MD	6,0 m
18737...		Abdeckprofil 50/7.5, selbstklebend Cover profile 50/7.5, self-adhesive	AS/ MD	6,0 m
17708...		Abdeckprofil 25/2.5, selbstklebend Cover profile 25/2.5, self-adhesive	AS/ MD	6,0 m

Art.-Nr. Art. No.	Abbildung Illustration	Benennung Description	Schüco LivIng	
17171...		Hohlkammer-Flachprofil 40/6 Hollow chamber flat profile 40/6	AS/ MD	6,0 m
17164...		Hohlkammer-Flachprofil 80/6 Hollow chamber flat profile 80/6	AS/ MD	6,0 m
17775...		Flachprofil 40/3 Flat profile 40/3	AS/ MD	6,0 m
18785...		Flachprofil 60/3 Flat profile 60/3	AS/ MD	6,0 m
18787...		Flachprofil 80/3 Flat profile 80/3	AS/ MD	6,0 m
17165...		Flachprofil 100/3 Flat profile 100/3	AS/ MD	6,0 m
17283...		Flachprofil 50/3 Flat profile 50/3	AS/ MD	6,0 m
18786...		Flachprofil 70/3 Flat profile 70/3	AS/ MD	6,0 m
18788...		Flachprofil 90/3 Flat profile 90/3	AS/ MD	6,0 m
17172...		Flachprofil 160/3 Flat profile 160/3	AS/ MD	6,0 m
17114...		Hohlkammer-Winkel 90/60/5 Hollow chamber angle 90/60/5	AS/ MD	6,0 m
18402...		Hohlkammer-Winkel 130/110/5 Hollow chamber angle 130/110/5	AS/ MD	6,0 m
18397...		Winkelprofil 30/15/3 Angled profile 30/15/3	AS/ MD	6,0 m
18398...		Winkelprofil 60/30/3 Angled profile 60/30/3	AS/ MD	6,0 m
18399...		Winkelprofil 100/60/3 Angled profile 100/60/3	AS/ MD	6,0 m

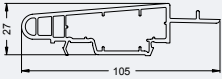
Art.-Nr. Art. No.	Abbildung Illustration	Benennung Description	Schüco LivIng	
18010...		Winkelprofil 160/55/3 Angled profile 160/55/3	AS/ MD	6,0 m
18781...		Winkelprofil 20/20/2,5 Angled profile 20/20/2.5	AS/ MD	6,0 m
18782...		Winkelprofil 30/30/2 Angled profile 30/30/2	AS/ MD	6,0 m
18783...		Winkelprofil 40/40/2 Angled profile 40/40/2	AS/ MD	6,0 m
17170...		Winkelprofil 50/50/3 Angled profile 50/50/3	AS/ MD	6,0 m
18784...		Winkelprofil 60/60/3 Angled profile 60/60/3	AS/ MD	6,0 m
18475...		Winkelprofil 80/80/3 Angled profile 80/80/3	AS/ MD	6,0 m
18375...		Wetterschenkel 15/23 Drip bar 15/23	AS/ MD	6,0 m
11394900		Alu-Adapter 10/4, gelocht (roh) Aluminium adapter 10/4, pre-punched (mill finish)	AS/ MD	6,0 m
17547...		Wetterschenkel 16/32 Drip bar 16/32	AS/ MD	6,0 m
11499700 11499710 11499790 17023...		Alu-Wetterschenkel 16/32 Aluminium drip bar 16/32	AS/ MD	6,0 m
17494...		Wetterschenkel 19,5/32 Drip bar 19.5/32	AS/ MD	6,0 m
13163500		Alu-Adapter 26/4, gelocht für 13163300 (roh) Aluminium adapter 26/4, pre-punched for 13163300 (mill finish)	AS/ MD	6,0 m
19838...		Wetterschenkel LivIng LivIng drip bar	AS/ MD	6,0 m
14709600 14709610 14709660 14709670		Alu-Wetterschenkel 38,7/10,5 Aluminium drip bar 38.7/10.5	AS/ MD	6,0 m

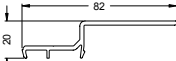
Art.-Nr. Art. No.	Abbildung Illustration	Benennung Description	Schüco LivIng	
11399400 11399410 11399460 11399470		Trittschutzprofil 18/32 Kick plate profile 18/32	AS/ MD	6,0 m
11499610 11499660 11499670		Trittschutzprofil 18/22 (weiß) Kick plate profile 18/22 (white)	AS/ MD	6,0 m
11499410 11499460 11499470		Trittschutzprofil 48/20 Kick plate profile 48/20	AS/ MD	6,0 m
11499510 11499560 11499570		Trittschutzprofil 61/20 Kick plate profile 61/20	AS/ MD	6,0 m
13168660		Trittschutzprofil 48/23 Kick plate profile 48/23	AS/ MD	6,5 m
18001...		Zargenprofil 22/40 Frame trim profile 22/40	AS/ MD	6,0 m
19090...		Zargenprofil 32/40 Frame trim profile 32/40	AS/ MD	6,0 m
18002...		Zargenprofil 42/40 Frame trim profile 42/40	AS/ MD	6,0 m
18376000		Zargenprofil 50/30 Frame trim profile 50/30	AS/ MD	6,0 m
18003...		Zargenprofil 62/40 Frame trim profile 62/40	AS/ MD	6,0 m
18004...		Zargenprofil 82/40 Frame trim profile 82/40	AS/ MD	6,0 m
19100...		Zargenprofil 92/40 Frame trim profile 92/40	AS/ MD	6,0 m
18005...		Zargenprofil 102/40 Frame trim profile 102/40	AS/ MD	6,0 m
18377...		Zargenprofil 100/30 Frame trim profile 100/30	AS/ MD	6,0 m
17212...		KS-Rohr 50/50 Plastic tube 50/50	AS/ MD	6,0 m
17203...		KS-Rohr 55/25 Plastic tube 55/25	AS/ MD	6,0 m
18374000		Klipsprofil 10 Clip-on profile 10	AS/ MD	6,0 m

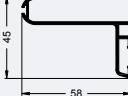
Art.-Nr. Art. No.	Abbildung Illustration	Benennung Description	Schüco LivIng	
18403000		Klipsprofil 8 Clip-on profile 8	AS/ MD	6,0 m
18927000		Klipsprofil 7 Clip-on profile 7	AS/ MD	6,5 m
18930...		Rollladenführung 40,5/61 Roller shutter guide 40,5/61	AS/ MD	6,0 m
18940...		Rollladenführung 40,5/61 Roller shutter guide 40,5/61	AS/ MD	6,0 m
19217...		Rollladenführung 47/62,5 Roller shutter guide 47/62,5	AS/ MD	6,0 m
18289...		Rollladenführung 47/72,5 Roller shutter guide 47/72,5	AS/ MD	6,0 m
18287...		Rollladenführung 47/36 Roller shutter guide 47/36	AS/ MD	6,0 m
13167200		Alu-Rollladenführung 47/36 Aluminium roller shutter guide 47/36	AS/ MD	6,0 m
18294...		Rollladenführung 33/43 Roller shutter guide 33/43	AS/ MD	6,0 m
19151...		Rollladenführung 42/43 Roller shutter guide 42/43	AS/ MD	6,5 m
13296800		Alu-Rollladenführung 42/43 Aluminium roller shutter guide 42/43	AS/ MD	6,0 m
18488...		Rollladenführung 43/33 Roller shutter guide 43/33	AS/ MD	6,0 m
18486...		Rollladenführung 42/33 Roller shutter guide 42/33	AS/ MD	6,0 m
17780000 17780150		Rollladentraverse Roller shutter traverse	AS/ MD	6,0 m
18049000 18049150		Rollladentraverse Roller shutter traverse	AS/ MD	6,0 m

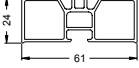
Art.-Nr. Art. No.	Abbildung Illustration	Benennung Description	Schüco LivIng	
19216000 19216150		Rolladentaverse Roller shutter traverse	AS/ MD	6,0 m
18020...		Kastenanschlussprofil Headbox attachment profile	AS/ MD	6,0 m
18298000		Kastenanschlussprofil Headbox attachment profile	AS/ MD	6,0 m
18480000 18480150		Adapterprofil 82/20 Adapter profile 82/20	AS/ MD	6,0 m
18018000 18018150 18018050 18018100		Abrollleiste 16/15 Top roller shutter guide 16/15	AS/ MD	6,0 m
18297000 18297150 18297100		Abrollleiste 5/15 Top roller shutter guide 5/15	AS/ MD	6,0 m
13296300		Alu-Abrollleiste 58/45 Aluminium top roller shutter guide 58/45	AS/ MD	6,0 m
18296...		Rolladen-Adapter 16/36 Roller shutter adapter 16/36	AS/ MD	6,0 m
18029...		Rolladen-Adapter 43/36 Roller shutter adapter 43/36	AS/ MD	6,0 m
19042...		Rolladen-Adapter 24/61 Roller shutter adapter 24/61	AS/ MD	6,0 m

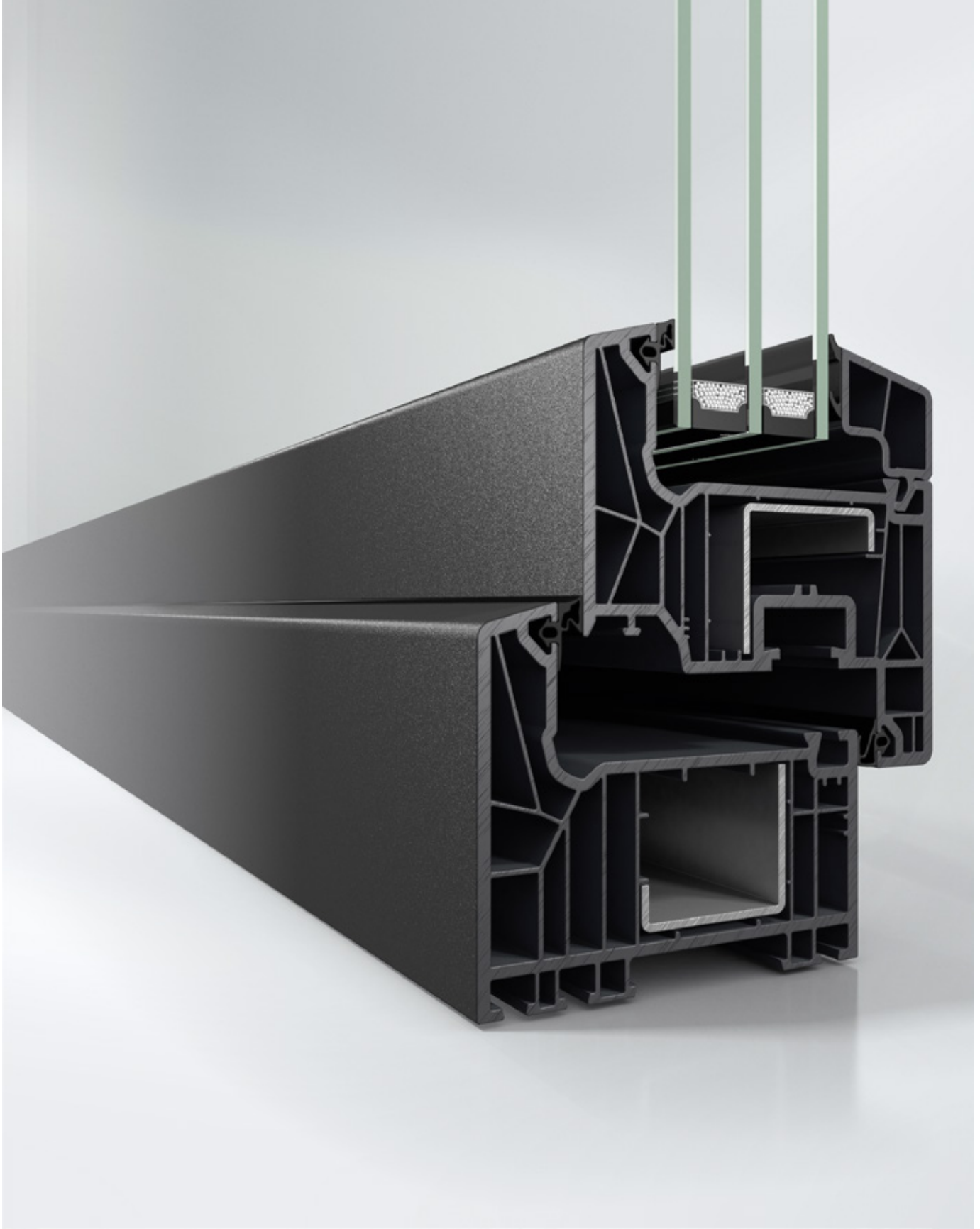



















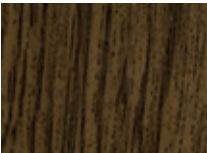





Folierung
Foiling

- 80 **Foliensortiment Schüco LivIng**
Range of foils for Schüco LivIng
- 85 **Systemeigenschaften Schüco AutomotiveFinish**
System features of Schüco AutomotiveFinish
- 86 **Systemverarbeitung**
System processing
- 88 **Schüco AutomotiveFinish**
Schüco AutomotiveFinish





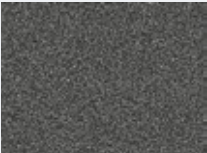



















Foliensortiment Schüco LivIng





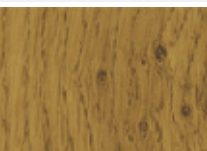

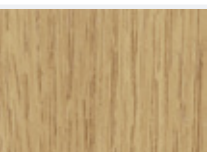















Range of foils for Schüco LivIng

Folien Lieferzeit | Foil delivery time |

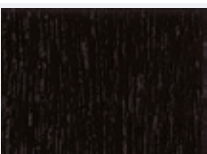













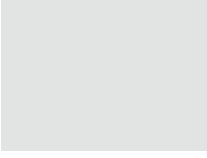

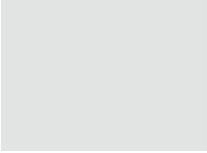

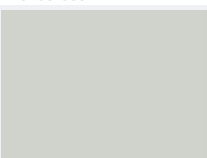

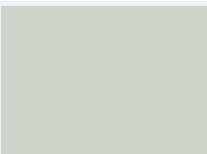

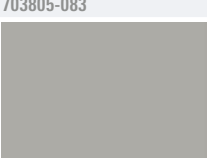







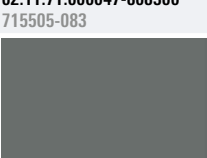

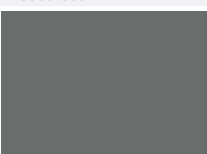

	Farbbezeichnung Colour description	Farbkürzel Colour ID		
 49158	Golden Oak Golden oak	GO	420	610
 9.2097 013-116700 2097013-167	Mahagoni Mahogany	MA	351	580
 436-2048	Nussbaum Walnut	NB	354	460
 02.11.81.00101-116700 851805-167	Braun Dekor Brown woodgrain	BD	356	590
 436-5003	Anthrazitgrau, ähnlich RAL 7016 Anthracite grey, similar to RAL 7016	AG	358	730
 436-7003	Anthrazitgrau, ähnlich RAL 7016 (glatt) Anthracite grey, similar to RAL 7016 (glossy)	AG	452	127
 02.11.71.000039-808300 701205-083	Basaltgrau, ähnlich RAL 7012 (glatt) Basalt grey, similar to RAL 7012 (glossy)	BG	—	126
 matt Matt	SAF-DB 703	DGM	—	601

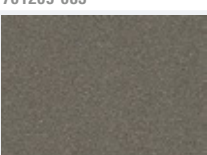
Folien Lieferzeit II ■ Foil delivery time II

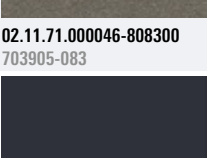
	Farbbezeichnung Colour description	Farbkürzel Colour ID		
 49197	Montana Montana	MT	131	760
 49198	Indian Indian	IN	132	770
 9.1192 001-116700 1192001-167	Oregon 4 Oregon 4	O4	134	620
 9.3069 041-116700 3069041-167	Bergkiefer Mountain pine	BK	135	630
 9.3152 009-116700 3152009-167	Douglasie Douglas fir	DG	136	600
 49195	Canadian Canadian	CA	133	780
 49240	Winchester XA Winchester XA	WXA	138	703
 9.3167 011-116700 3167011-167	Eiche, natur Natural oak	EN	137	—

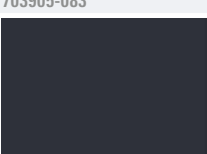
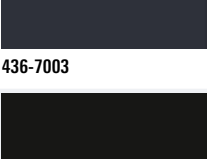
	Farbbezeichnung Colour description	Farbkürzel Colour ID		
 9.3167 002-116700 3167002-168	Eiche, hell Light oak	EH	139	400
 9.3167 004-116700 3167004-167	Eiche, dunkel Dark oak	ED	355	570
 49233	Siena Rosso Siena rosso	SR	352	910
 49237	Siena Noce Siena noce	SN	353	900
 436-2048	Nussbaum Walnut	NB	354	460
 02.11.81.00101-116700 851805-167	Braun Dekor Brown woodgrain	BD	356	590
 02.11.61.000013-116700 600505-167	Moosgrün, ähnlich RAL 6005 Moss green, similar to RAL 6005	MG	—	740
 436-5021	Tannengrün, ähnlich RAL 6009 Fir green, similar to RAL 6009	GN	—	890

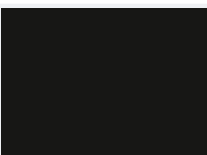
	Farbbezeichnung Colour description	Farbkürzel Colour ID		
 02.11.51.000028-116700 500705-167	Brilliantblau, ähnlich RAL 5007 Brilliant blue, similar to RAL 5007	BB	—	710
 02.11.51.000033-116700 515005-167	Stahlblau, ähnlich RAL 5011 Steel blue, similar to RAL 5011	SB	—	830
 02.11.31.000013-116700 308105-167	Rot, ähnlich RAL 3011 Red, similar to RAL 3011	RT	—	870
 436-1001	Aluminium gebürstet Brushed aluminium	ALG	—	702
 436-1002	Metallic Silber Metallic silver	MS	—	701
 02.11.71.000047-116700 715505-167	Silbergrau, ähnlich RAL 7001 Silver grey, similar to RAL 7001	SG	670 357	700
 02.11.71.000039-116700 701205-167	Basaltgrau, ähnlich RAL 7012 Basalt grey, similar to RAL 7012	BG	183 359	158
 02.11.71.000046-116700 703905-167	Quarzgrau, ähnlich RAL 7039 Quartz grey, similar to RAL 7039	QGR	538 361	537

	Farbbezeichnung Colour description	Farbkürzel Colour ID		
 436-5003	Anthrazitgrau, ähnlich RAL 7016 Anthracite grey, similar to RAL 7016	AG	154 358	730
 02.11.71.000049-808300 725105-083	Lichtgrau, ähnlich RAL 7035 (glatt) Light grey, similar to RAL 7035 (glossy)	LG	182 453	122
 02.11.71.000045-808300 703805-083	Achatgrau, ähnlich RAL 7038 (glatt) Agate, similar to RAL 7038 (glossy)	AC	516 454	123
 02.11.71.000038-808300 700405-083	Signalgrau, ähnlich RAL 7004 (glatt) Signal grey, similar to RAL 7004 (glossy)	SI	178 455	124
 02.11.71.000047-808300 715505-083	Silbergrau, ähnlich RAL 7001 (glatt) Silver grey, similar to RAL 7001 (glossy)	SG	179 456	125
 02.11.71.000039-808300 701205-083	Basaltgrau, ähnlich RAL 7012 (glatt) Basalt grey, similar to RAL 7012 (glossy)	BG	173 451	126
 02.11.71.000046-808300 703905-083	Quarzgrau, ähnlich RAL 7039 (glatt) Quartz grey, similar to RAL 7039 (glossy)	QGR	547 458	541
 436-7003	Anthrazitgrau, ähnlich RAL 7016 (glatt) Anthracite grey, similar to RAL 7016 (glossy)	AG	156	127
 02.11.71.000042-808300 702105-083	Schwarzgrau, ähnlich RAL 7021 (glatt) Dark grey, similar to RAL 7021 (glossy)	SC	533 457	128

Systemeigenschaften Schüco AutomotiveFinish

System features of Schüco AutomotiveFinish

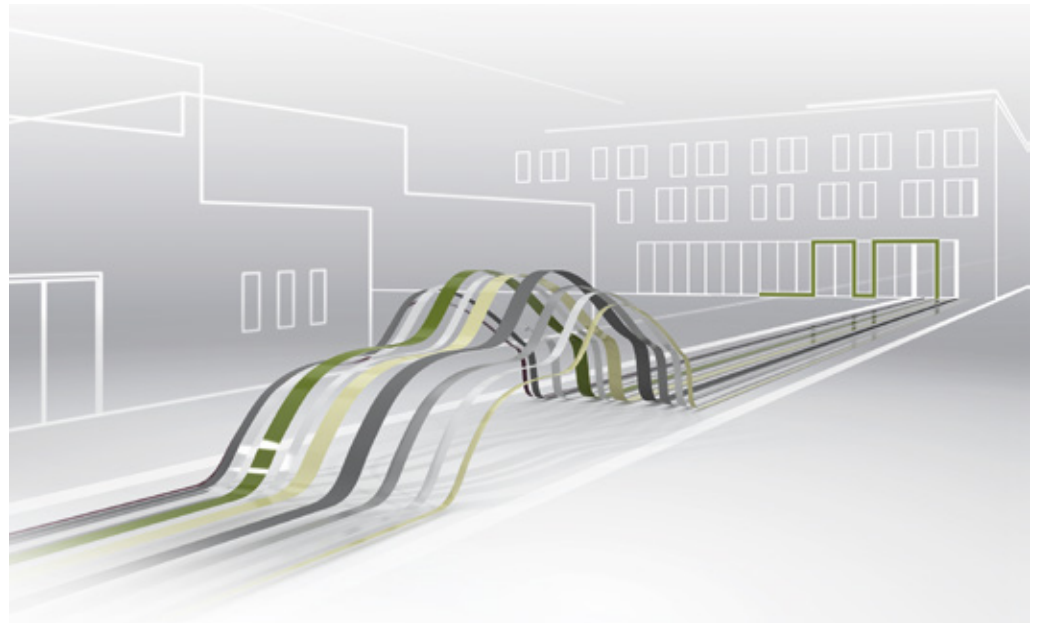

Schüco AutomotiveFinish ist ein völlig neues Farbgebungsverfahren und wurde zwischen Schüco und einem führenden Hersteller der Automobillackindustrie entwickelt. Herausgekommen sind brillante Metallicöne, welche in einem umweltfreundlichen und ressourcenschonenden Herstellungsprozess produziert werden können.

Metallicoptik auf Kunststoff ist die Kombination von einer brillanten Oberfläche mit den Verarbeitungsvorteilen des Werkstoffes Kunststoff. Schüco AutomotiveFinish eröffnet eine neue erstklassige Gestaltungsvielfalt für den Innen- und Außenbereich. Die hochwertige Oberflächenbeschichtung weist eine hervorragende Farb- und Witterungsbeständigkeit auf, welche von den hohen technischen Anforderungen aus der Automobilindustrie adaptiert wurde.

Bei den Farben DB703, RAL 9006 und RAL 9007 handelt es sich um sehr umsatzstarke Grautöne in der Baubranche. Die Farben RAL 750-M, RAL 450-M, RAL 140-M, RAL 630-M und RAL 350-M sind RAL-Effect Farben und z.B. im RAL-Farb-fächer E4 enthalten. Die Farben White Line, Copper Effect und Cream Line zeichnen sich vor allem durch das Zusammenspiel von Farbe und Struktur aus.

Schüco AutomotiveFinish is a completely new colour application process and has been developed by Schüco in conjunction with a leading manufacturer in the automotive coating industry. The result is brilliant metallic shades that can be produced by means of an environmentally friendly manufacturing process which also conserves resources.

The metallic-look on PVC-U is the combination of a brilliant surface finish with the fabrication benefits of PVC-U. Schüco AutomotiveFinish opens up new, high-quality design opportunities for both inside and outside. The high-quality coating provides outstanding colourfastness and weather resistance, which has been adapted to fulfil the high technical requirements from the automotive industry.

The colours DB703, RAL 9006 and RAL 9007 are very popular shades of grey in the construction industry. The colours RAL 750-M, RAL 450-M, RAL 140-M, RAL 630-M and RAL 350-M are RAL Effect colours and are included in the E4 colour chart for example. A distinguishing feature of the White Line, Copper Effect and Cream Line colours is above all the interplay of colour and structure.

Systemverarbeitung

System processing



Kreative Möglichkeiten bei der außen- und innenseitigen Gestaltung durch neue gestalterische Impulse mit Schüco AutomotiveFinish
Creative freedom in external and internal design thanks to new design inspirations with Schüco AutomotiveFinish.

Die Verarbeitung ist gleich den heute bekannten folienkaschierten Profilen und kann mit der vorhandenen Maschinen- und Anlagentechnik durchgeführt werden. Für die Verarbeitung von Schüco AutomotiveFinish gelten generell die Verarbeitungsrichtlinien für farbige Oberflächen. Wir liefern Ihnen auch die dazugehörigen Farbstifte für die Schweißnutbearbeitung sowie Sprühdosen für die farbliche Anpassung einzelner Kappen und Kleinteile.

Achtung!

Bitte beachten Sie, dass die Schüco AutomotiveFinish Folien nur auf Classic Flügelkonturen kaschiert werden.

Bedingt durch die speziellen technischen Eigenschaften ergeben sich folgende Einschränkungen:

Wir haben festgestellt, dass der Biegeprozess die Oberfläche von Schüco AutomotiveFinish stark beeinträchtigt und es im Extremfall zu Rissen in der Oberfläche kommen kann. Aus diesem Grund raten wir davon ab Profile mit Schüco AutomotiveFinish zu biegen bzw. solche Elemente einzubauen.

Knickleisten wie z.B. die Artikel 17283..., 18786..., 18788..., 17172... werden in Schüco AutomotiveFinish nicht angeboten, da eine dynamische Beanspruchung von kaschierten Schüco AutomotiveFinish-Profilen nicht möglich ist.

Processing follows the same method that is currently used for conventional foiled profiles, and can be carried out using the existing machines and system technology. When processing Schüco AutomotiveFinish, in general the fabrication guidelines for coloured surfaces apply. We also provide you with the corresponding touch-up stick for processing the weld grooves, and aerosols for colour-matching the caps and small components.

Important:

Please note that the Schüco AutomotiveFinish foils can only be laminated on Classic vent contours.

Depending on the special technical features, the following limitations apply:

We have established that the bending process severely impairs the Schüco AutomotiveFinish surface finish, and that in extreme cases, cracks may occur in the surface finish. For this reason, we advise against bending profiles with the Schüco AutomotiveFinish, or installing such units.

Flexible flats such as articles 17283, 18786, 18788 and 17172, are not offered in Schüco AutomotiveFinish, as the dynamic loading of laminated Schüco AutomotiveFinish profiles is not possible.





Einige Spezifikationen bei der Be- und Verarbeitung von Schüco AutomotiveFinish müssen beachtet werden:

Some specifications must be observed when processing the Schüco AutomotiveFinish.

Zuschnitt:

Bitte beachten Sie, dass die Sägeblätter Ihrer Doppelgehrungssägen mangelfrei sind.

Cutting:

Please ensure that the saw blades of your double-headed mitre saw are free of defects.

Begrenzungsmesser der Schweißmaschine:

Die Begrenzungsmesser Ihrer Schweißmaschine für die Verarbeitung von Dekorprofilen müssen mangelfrei sein.

Limiting cutters of the welding machine:

The limiting cutters of your welding machine for processing the woodgrain profiles must be free of defects.

Verschweißung:

Nach jedem Arbeitsgang, spätestens jedoch vor dem Verschweißen, müssen die Profile auf Sauberkeit geprüft werden und von Spänen befreit sowie ausgeblasen werden. Auf den Profilen angebrachte lose Schutzfolien sind mindestens 10 cm auf beiden Seiten abzuschneiden.

Welding:

After each operation, but at the latest prior to welding, it must be checked that the profiles are clean and that any swarf is blown out. With protective foils loosely applied to the profiles, at least 10 cm must be cut off on both sides.

Messersätze für Eckenputzer:

Für die Verarbeitung der Schüco AutomotiveFinish Folien ist es erforderlich ihre jeweiligen Messersätze der Eckenputzer alle 5000 Fenstereinheiten zu tauschen. Weiterhin wird empfohlen, jeweils einen kompletten Messersatz als Reserve auf Lager zu halten. Sollten sich noch Folienreste an der verputzten Ecke befinden, entfernen Sie diese bitte vorsichtig mit einem geeigneten Werkzeug.

Cutting tool assemblies for corner cleaners:













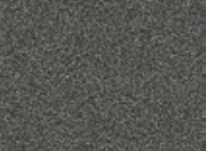

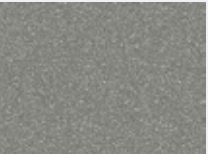







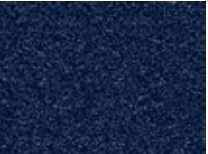

When processing the Schüco AutomotiveFinish foils, it is necessary to replace the respective cutting tool assemblies for the corner cleaners after every 5000 window units. It is also recommended that a complete cutting tool assembly is kept in stock in reserve.

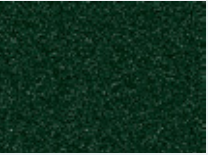

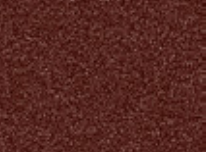







If there is any further foil at the cleaned corner, please remove this carefully with a suitable tool.

Schüco AutomotiveFinish

Schüco AutomotiveFinish

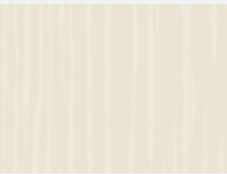
Folierung
Foiling

	Farbbezeichnung Colour description	Farbkürzel Colour ID			
 matt Matt	SAF-DB 703	DGM	301 362	—	—
 semigloss Semi-gloss	SAF-RAL 9007	GRM	303 363	603	—
 semigloss Semi-gloss	SAF-RAL 9006	SM	302 364	602	—
 semigloss Semi-gloss	SAF-RAL 140-M	GM	306	606	—
 semigloss Semi-gloss	SAF-RAL 630-M	BLM	307	607	—
 semigloss Semi-gloss	SAF-RAL 750-M	GNM	304	604	—
 semigloss Semi-gloss	SAF-RAL 350-M	BNM	308	608	—
 semigloss Semi-gloss	SAF-RAL 450-M	RTM	305	605	—

	Farbbezeichnung Colour description	Farbkürzel Colour ID			
	SAF-White Line	PWS	312	612	—
	SAF-Cream Line	PBS	—	—	611
	SAF-Copper Effect	BRS	—	—	609



Verglasung
Glazing

- 92 Verglasung
Glazing
- 93 Glasleisten Schüco LivIng
Glazing beads for Schüco LivIng
- 95 Verglasungsmöglichkeiten
Glazing options
- 96 Sortiment Klotzbrücken
Range of glazing bridges
- 99 Verglasungsklötze
Glazing blocks
- 100 Additive Klebetechnik
Additive adhesive technology
- 108 Dämmfalzeinleger
Insulating rebate inserts
- 109 Ziersprossen
Decorative sash bars

Verglasung Glazing

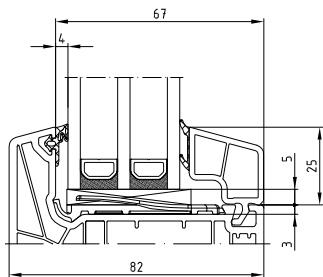

Verglasung Schüco LivIng 82 AS
Schüco LivIng 82 AS Glazing

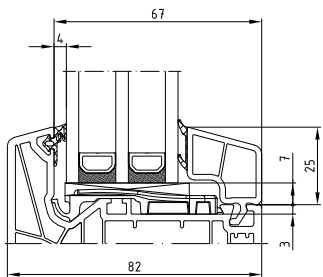

Verglasung Schüco LivIng 82 MD
Schüco LivIng 82 MD Glazing

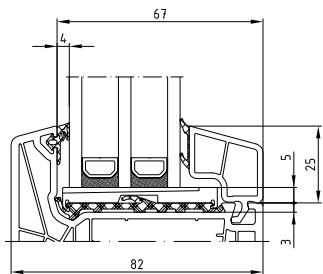

Verglasung Schüco LivIng, geklebt
Schüco LivIng Glazing, bonded

Mitteltende Normen

Für die Verglasung und Verklötzung gelten die folgenden Normen und technischen Regelwerke, vorrangig aber abweichende Angaben des Systemgebers:

- DIN 18361 Vergabe- und Vertragsordnung für Bauleistungen (VOB), Teil C - Verglasungsarbeiten
- Technische Richtlinien des Glaserhandwerkes herausgegeben vom Bundesinnungsverband des Glaserhandwerkes:
 - Richtlinie Nr. 3 - Klotzung von Verglasungseinheiten
 - Richtlinie Nr. 8 - Verkehrssicherheit mit Glas in öffentlichen Verkehrsbereichen
 - Richtlinie Nr. 9 - Visuelle Prüf- und Bewertungsgrundsätze für Verglasungen am Bau
 - Richtlinie Nr. 17 - Verglasen mit Isolierglas
 - Richtlinie Nr. 18 - Absturzsichernde Verglasungen nach TRAV
 - Richtlinie Nr. 19 - Linien- und punktförmig gelagerte Verglasungen
- Anhang C der Produktnorm EN 14351-1 „Normen und Norm-Entwürfe für Glas“

Hinweise

Es sind die z.T. hohen zulässigen Glastoleranzen, gemäß DIN EN 1279-1, zu beachten, die z.B. bei 3-fach-Gläsern +2,8/-1,4 mm betragen können.

Other applicable standards

For glazing and blocking, the standards and technical rules below apply, however, if guidelines from the system provider are different, these take precedence.

- DIN 18361 German Construction Contract Procedures (VOB), Part C - Glazing Works
- Technical guidelines of the glazing industry issued by the German Glazier Guild:
 - Guideline No. 3 - Blocking of glazing units
 - Guideline No. 8 - Safety when transporting glass in public areas
 - Guideline No. 9 - Visual inspection and evaluation principles for glazing on buildings
 - Guideline No. 17 - Glazing with insulating glass
 - Guideline No. 18 - Safety barrier glazing in accordance with TRAV
 - Guideline No. 19 - Glazing held in by pressure plates and point-fixed glazing
- Appendix C of the product standard EN 14351-1 "standards and draft standards for glass"

Notes

The permissible glass tolerances, which are sometimes high, must be observed in accordance with DIN EN 1279-1. For example, they may be +2.8/-1.4 mm for triple glazing.

Glasleisten Schüco LivIng

Glazing beads for Schüco LivIng

Glasleiste 8/25
Glazing bead 8/25
19550...



52

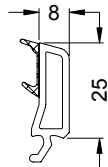

Glasleiste 18/25
Glazing bead 18/25
19555...



42

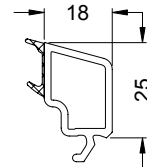

Glasleiste 10/25
Glazing bead 10/25
19551...



50

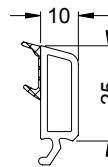

Glasleiste 20/25
Glazing bead 20/25
19556...



40

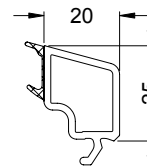

Glasleiste 12/25
Glazing bead 12/25
19552...



48

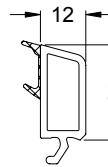

Glasleiste 22/25
Glazing bead 22/25
19557...



38

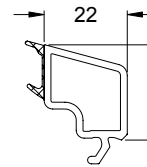

Glasleiste 14/25
Glazing bead 14/25
19553...



46

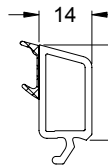

Glasleiste 24/25
Glazing bead 24/25
19558...



36

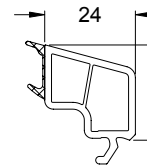

Glasleiste 16/25
Glazing bead 16/25
19554...



44

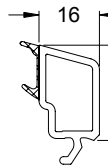

Glasleiste 26/25
Glazing bead 26/25
19559...



34

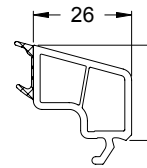

Glasleiste 28/25
Glazing bead 28/25
19560...

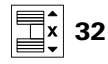
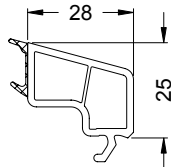

32

Glasleiste 34/25
Glazing bead 34/25
19563...

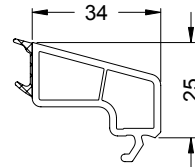

26

Glasleiste 30/25
Glazing bead 30/25
19561...

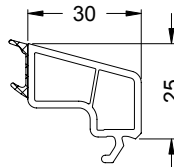

30

Glasleiste 36/25
Glazing bead 36/25
19564...

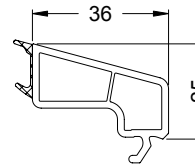

24

Glasleiste 32/25
Glazing bead 32/25
19562...

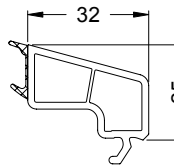

28

Design Glasleisten Schüco LivIng Feature glazing beads for Schüco LivIng

Glasleiste 16/25
Glazing bead 16/25
19584...

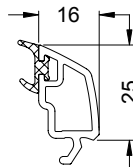

44

Glasleiste 24/25
Glazing bead 24/25
19588...

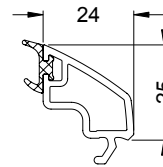

36

Glasleiste 20/25
Glazing bead 20/25
19586...

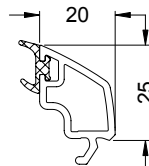

40

Glasleiste 28/25
Glazing bead 28/25
19590...

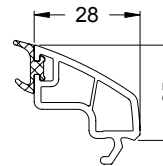

32

Verglasungsmöglichkeiten

Glazing options

Bautiefe 82 mm, Glasfalzbreite 67 mm Basic depth 82 mm, glazing rebate width 67 mm

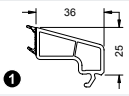
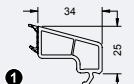
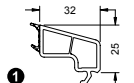
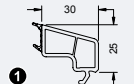
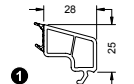
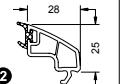
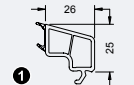
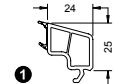
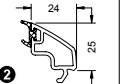
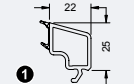
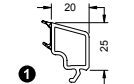
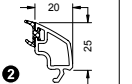
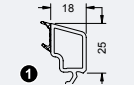
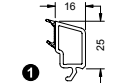
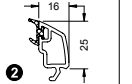
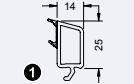
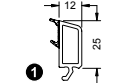
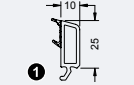
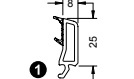
Glasleisten mit Dichtung Glazing beads with gasket		
Abbildung Illustration		Art.-Nr. Art. No.
24 mm 		① 19564...
26 mm 		① 19563...
28 mm 		① 19562...
30 mm 		① 19561...
32 mm  		① 19560... ② 19590...
34 mm 		① 19559...
36 mm  		① 19558... ② 19588...
38 mm 		① 19557...
40 mm  		① 19556... ② 19586...
42 mm 		① 19555...
44 mm  		① 19554... ② 19584...
46 mm 		① 19553...
48 mm 		① 19552...
50 mm 		① 19551...
52 mm 		① 19550...

Die Werte basieren auf den Glas-Nennmaßen der jeweiligen Glashersteller. Das Glas-Ist-Maß ist zu kontrollieren. Die Glasleistendichtungen besitzen eine Toleranz von +1 mm und können somit abweichende Glasstärken abfangen.

The values are based on the nominal glass sizes of the respective glass manufacturer. Check the actual glass size. The glazing bead gaskets have a tolerance of +1 mm and can therefore accommodate variances in glass thickness.

Sortiment der Klotzbrücken







Range of glazing bridges

Eigenschaften der Schüco Klotzbrücken

- Seitliche Sicherungsfedern zur Sicherung des Verglasungsklotzes gegen Verrutschen
- Optimierte Klemmung im Profil, auch bei auftretenden Toleranzen
- Schüco Klotzbrücken sind laut den Allgemeinen Planungs- und Verarbeitungshinweisen sowie den aktuellen technischen Richtlinien des Glaserhandwerks zu verarbeiten.

Features of the Schüco glazing bridges

- Side retaining springs secure the glazing block against slippage
- They are held firmly in the profile, even where tolerances occur
- Schüco glazing bridges must be used in accordance with the general design and fabrication instructions and the current technical guidelines issued by the German glazier guild.

Klotzbrücken Glazing bridges				
	als Tragklotz As support block		als Distanzklotz As spacer block	
Schüco LivIng 82 AS		 25094900	 25096600	  25094800
Schüco LivIng 82 MD		 25094700	—	—



passend für alle Blendrahmen- und T-Profile



passend für alle Flügelrahmenprofile (außer Flügel mit Additiver Klebetechnik)



passend für Flügel mit Additiver Klebetechnik



Suitable for all outer frame and T-profiles



Suitable for all vent frame profiles (exception: vents with additive adhesive technology)



Suitable for vents with additive adhesive technology

Klotzbrücken, Glasfalzbreite 67 mm Glazing bridges, glazing rebate width 67 mm

Klotzbrücke ■ Glazing bridge

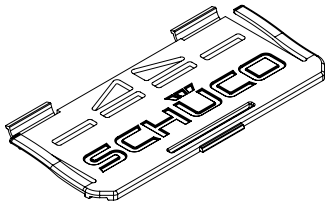
25094900 braun ■ Brown

- Tragklotz für 3 mm Falztiefe
- einsetzbar für Schüco LivIng 82 AS
- Support block for 3 mm rebate depth
- Can be used for Schüco LivIng 82 AS

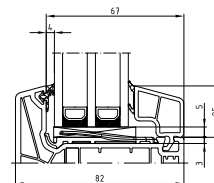

Klotzbrücke ■ Glazing bridge

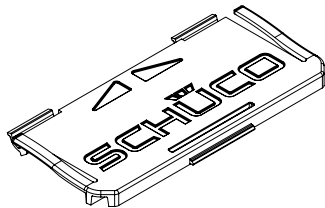
25094700 orange ■ Orange

- Trag- und Distanzklotz für 3 mm Falztiefe
- einsetzbar für Schüco LivIng 82 MD
- Support and spacer block for 3 mm rebate depth
- Can be used for Schüco LivIng 82 MD

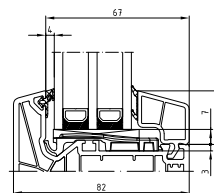

Klotzbrücke ■ Glazing bridge

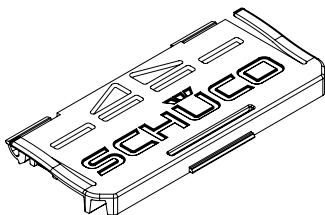
25094800 violett ■ Violet

- Distanzklotz für 3 mm Falztiefe
- einsetzbar für Schüco LivIng 82 AS
- Spacer block for 3 mm rebate depth
- Can be used for Schüco LivIng 82 AS

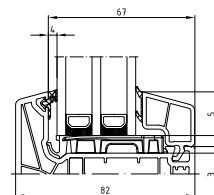

Klotzbrücke ■ Glazing bridge

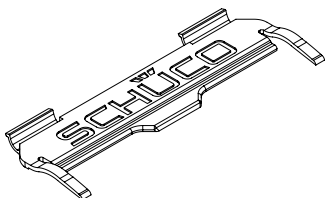
25096600 dunkelblau ■ Dark blue

- Tragklotz für 0 mm Falztiefe
- einsetzbar für Klebeflügel Schüco LivIng
- Support block for 0 mm rebate depth
- Can be used for Schüco LivIng adhesive vents

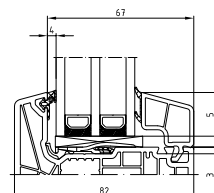

Lastabtragungsklotz 67 mm ■ Load transfer block 67 mm
28645300 schwarz ■ Black

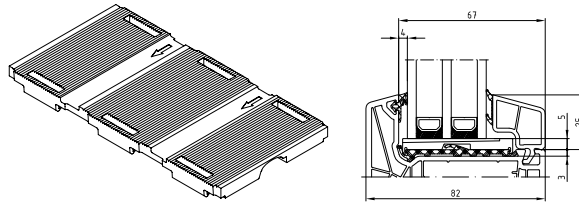

Einsatz von Klotzbrücken Schüco LivIng Use of glazing bridges Schüco LivIng

Drehflügel Side-hung vent

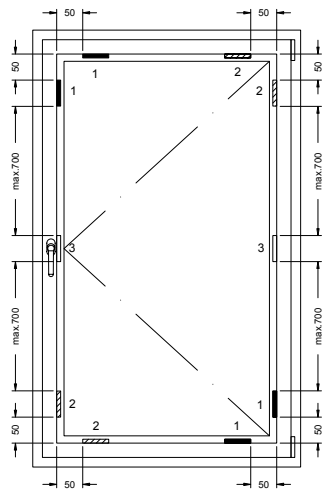

Drehkippflügel Turn/tilt vent

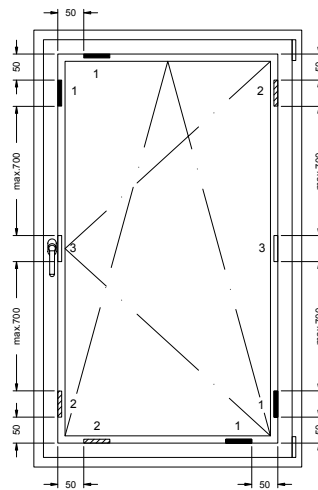

Festverglasung Fixed glazing

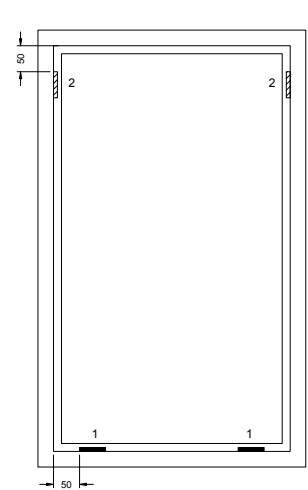

■ Tragklotz
Support block

▨ Distanzklotz
Spacer block

□ zusätzliche Distanzklotze in Abhängigkeit von
der Elementhöhe
Additional spacer blocks depending on the unit
height

Verglasungsklotze

Glazing blocks

Die Verglasungsklotze sollten mindestens 100 mm lang und generell breiter als das zu tragende Glas sein.

The glazing blocks should be at least 100 mm long and generally wider than the glass to be carried.

Art.-Nr. Art. No.	Abbildung Illustration	Benennung Description			
25074000		Verglasungsklotz 100x30 Glazing block 100 x 30	2 mm	rot Red	500 Stk.
25074100			3 mm	grün Green	
25074200			4 mm	gelb Yellow	
25074300			5 mm	blau Blue	
25074400			6 mm	schwarz Black	
25074500				Verglasungsklotz 100x40 Glazing block 100 x 40	
25074600	3 mm	grün Green			
25074700	4 mm	gelb Yellow			
25074800	5 mm	blau Blue			
25074900	6 mm	schwarz Black			
25075000		Verglasungsklotz 100x50 Glazing block 100 x 50	2 mm	rot Red	100 Stk.
25075100			3 mm	grün Green	
25075200			4 mm	gelb Yellow	
25075300			5 mm	blau Blue	
25075400			6 mm	schwarz Black	
25235000		Verglasungsklotz 100x54 Glazing block 100 x 54	2 mm	rot Red	100 Stk.
25235100			3 mm	grün Green	
25235200			4 mm	gelb Yellow	
25235300			5 mm	blau Blue	
25235400			6 mm	schwarz Black	

Additive Klebetechnik

Additive adhesive technology

Systemeigenschaften Additive Klebetechnik

System features - Additive adhesive technology

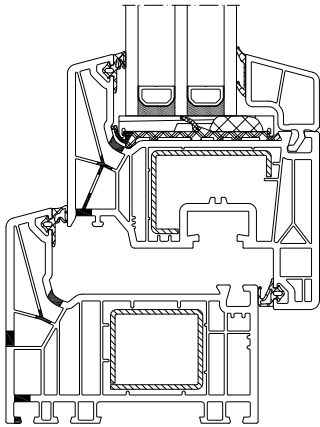

Additive Klebetechnik
Schüco LivIng 82 AS
Additive adhesive technology
Schüco LivIng 82 AS

Die Additive Klebetechnik von Schüco ist eine neu entwickelte Verklebung von Glas und Flügelrahmen. Ziel dieser Technologie ist die Verbesserung der Steifigkeit von Fenster- und Türkonstruktionen. Dabei wird das statische Element des Glases durch Verklebung auf den Fensterflügel bzw. den Türflügel (Türblatt) übertragen. Ebenso ist der Einsatz der Additiven Klebetechnik bei Festelementen möglich.

Bei der Additiven Klebetechnik handelt es sich um ein optionales Verfahren, welches während der standardisierten Fensterproduktion nur im Bedarfsfall Anwendung findet. Dabei werden die Standardprofile verwendet.

Folgende Vorteile ergeben sich mit der Additiven Klebetechnik:

- Verbesserung der Stabilität von Fenster- und Türelementen
- Erhöhung der Elementgrößen
- Kein Hängen oder Setzen des Flügels nach der Montage
- Reduzierung der Arbeiten zur Flügeljustierung auf der Baustelle
- Keine gesonderten Flügelprofile notwendig
- Verfahren in standardisierten Fertigungsablauf integrierbar
- Keine Investitionen in teure Maschinenteknik zur Verklebung notwendig
- Sofortiger Weitertransport der Elemente nach Verklebung und Verglasung möglich
- Verglasung auf der Baustelle möglich
- an bestehenden Schüco Elementen nachrüstbar

Additive adhesive technology from Schüco is a newly developed form of bonding for glass and vent frames. The aim of this technology is to improve the stability of window and door constructions. The structural element of the glass is transferred to the window vent or door leaf by bonding. Additive adhesive technology can also be used for fixed units.

Additive adhesive technology is an optional procedure, which is only used if necessary during standardised window production. Standard profiles are used in this process.

The benefits of additive adhesive technology are as follows:

- Improvement in stability of window and door units
- Unit sizes are increased
- No need to hang or position the vent after installation
- Less work to adjust the vent on site
- No special vent profiles required
- Procedure can be integrated into the standardised production process
- No need for investment in expensive bonding machine technology
- Units can be immediately transported after bonding and the installation of glazing
- Glazing can be done on site
- Can be retrofitted to existing Schüco units

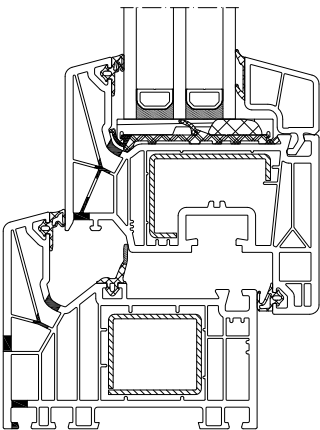

Additive Klebetechnik
Schüco LivIng 82 MD
Additive adhesive technology
Schüco LivIng 82 MD

Komfort

- Verarbeitung in standardisierter Fensterproduktion möglich
- Ohne hohe Investitionen oder teure Umbaumaßnahmen
- Keine gesonderten Flügelprofile erforderlich
- Verringerte Einstell- und Justierarbeiten des Flügels auf der Baustelle

Design

- Farbliche Gestaltung der Profile durch eine große Auswahl an Holz- und Uni-Dekorfolien auch bei der additiven Klebetechnik möglich
- Zur Integration in Aluminium-Fassaden steht das Komplettsortiment Aluminium-Deckschalen auch für die additive Klebetechnik zur Verfügung

Systemverarbeitung

- Einfaches einklipsen der zusätzlichen Falzeinlage in die 6m-Stange des Flügel- bzw. Blendrahmenprofils
- Schaffung einer definierten Klebefuge für optimale Festigkeit und Elastizität
- Minimaler Klebstoffbedarf
- Weitere Stabbearbeitung und Rahmenschneidung auf herkömmliche Art und Weise
- Verschraubung der Falzeinlage mit der Stahlarmierung sichert eine schubfeste Verbindung
- Auftretende Kräfte werden direkt über Bänder und Lager auf den Rahmen und das umgebende Mauerwerk abgeleitet
- Keine Trocknungs- und Aushärtezeiten notwendig
- Sofortige Weiterverarbeitung bzw. Transport möglich

Comfort

- Procedure can be used in standardised window production
- No high-level investment or expensive conversion work necessary
- No special vent profiles required
- Less requirement for adjustment of the vent on site

Design

- Profiles in coloured designs can be produced with a large selection of woodgrains and single colour decorative foils, even when additive adhesive technology is used
- For integration in aluminium façades, the complete range of aluminium cover caps is also available for additive adhesive technology

System processing

- The additional rebate insert simply clips into the 6 m bar of the vent or outer frame profile
- Creation of a defined bonding joint for optimum stability and elasticity
- Minimal amount of adhesive is required
- Further profile processing and frame fabrication by conventional means
- The rebate insert is screwed to the steel reinforcement, which guarantees a shear-resistant connection
- All forces are channeled directly through the hinges and bearings on the frame and the surrounding masonry
- No drying or curing time is required
- Further processing and transportation is possible immediately

Falzeinlage 67/3 ■ Rebate insert 67/3
19640000

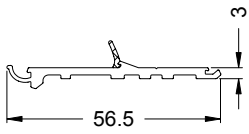



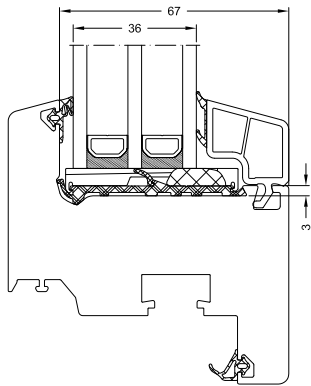





Einbausituation ■ Installation location



Achtung:
Die Verarbeitung dieser Falzeinlage ist nur mit einer 3-fach-Verglasung möglich!

Note:
Fabrication of this rebate insert is only possible with triple glazing.

Art.-Nr. Art. No.	Abbildung Illustration	Benennung Description			
28645300		Lastabtragungsklotz 67 mm Load transfer block 67 mm	schwarz Black	100 Stk.	—
28653500		Distanzstück 11 mm Spacer 11 mm	gelb Yellow	20 Stk.	—
28645400		Distanzstück 12 mm Spacer 12 mm	grün Green	100 Stk.	—
28645500		Distanzstück 13 mm Spacer 13 mm	rot Red	20 Stk.	—
28645600		Zentrierklotz Centring block	schwarz Black	100 Stk.	—

Wartung, Reparatur und Entsorgung Maintenance, repair and disposal

Wartung

Die Additive Klebetechnik ist grundsätzlich wartungsfrei. Ein Senken des Flügels während der Gebrauchsdauer kann bei funktionsfähiger Verklebung nicht eintreten. Dementsprechend ist kein „Nachklotzen“ nach der Elementmontage notwendig.

Die üblichen Wartungsarbeiten hinsichtlich der Funktionsfähigkeit der Beschläge, Profile und Dichtungen sowie das Reinigen der Bauteile ist regelmäßig gemäß der Pflegeanleitung Schüco EasyCare durchzuführen.

Reparatur

Im Falle eines Scheibenwechsels ist wie folgt vorzugehen:

1. Entfernen der Glasleiste
2. Aufschneiden der Klebefuge mit einem Cuttermesser oder Multifunktionswerkzeug (z.B. Fein Multimaster)
3. Entnehmen der Scheibe
4. Anschließend die Arbeitsschritte gemäß „Verglasung“ durchführen

Entsorgung

Nach Ablauf der Lebensdauer eines Bauelementes mit Additiver Klebetechnik können die Einzelkomponenten zum Zwecke des Recyclings voneinander getrennt werden. Hierbei ist zu verfahren wie unter Reparatur Punkt 1-3 beschrieben.

Maintenance

In principle, additive adhesive technology requires no maintenance. If bonded correctly, a vent will not be able to “settle” during its useful life. There is therefore no need to adjust the unit after it has been installed.

All the usual maintenance work in relation to correct functioning of the fittings, profiles and gaskets, as well as the cleaning of the components, must be carried out regularly in accordance with the Schüco EasyCare maintenance instructions.

Repair

If a pane of glass needs replacing, proceed as follows:

1. Remove the glazing bead
2. Cut open the bonded joint using a cutting knife or multi-purpose tool (e.g. Fein Multimaster)
3. Remove the pane of glass
4. Then take the steps in accordance with “Glazing”

Disposal

Once the service life of a building component with additive adhesive technology has come to an end, the individual components can be dismantled for the purpose of recycling. Proceed as described under “Repair”, points 1-3.

Empfohlene Primer und Klebstoffe Recommended primers and adhesives

Verglasung

Achtung:
Um die Klebkraft zu gewährleisten muss die Oberflächentemperatur des einzusetzenden Glases mindestens 15°C betragen.

Vorbehandlung beim Einsatz von Klebstoffen der Otto-Chemie GmbH:
Pre-treatment when using adhesives from Otto-Chemie GmbH:

Die Haftflächen im Glasfalzbereich müssen sauber und fettfrei sowie frei von Ölen, Staub, Wasser, Dichtstoffen oder Trennmitteln sein.

Zur Reinigung der Klebeflächen sind diese vor Beginn der Glasmontage vorzubehandeln (z.B. mit OTTO Cleanprimer 1226). Dies gilt sowohl für den Sekundärrandverbund als auch für die Falzeinlage. Der Primer muss mit einem sauberen, fusselfreien Tuch aufgetragen werden.

Nachwischen oder mehrfaches Auftragen des Primers ist nicht zulässig.

Primer und Klebstoff müssen aufeinander abgestimmt sein und vom Hersteller bzw. Lieferanten freigegeben werden.

Der Randbereich des Glases ist auf Beschädigungen und Verunreinigungen zu kontrollieren. Es darf nur unbeschädigtes Glas verarbeitet werden.

Im Fall von Verunreinigungen der Klebefläche, wie Sekundärdichtstoff, Ölen, Staub, Wasser oder Trennmitteln, sind diese rückstandslos zu entfernen. Anschließend ist die Glaskante zu primern. Die Hinweise des Herstellers zur Anwendung des Primers sind zu beachten.

Glazing

Note:
To guarantee the adhesive properties, the surface temperature of the glass to be used must be at least 15°C.

The bonding surfaces in the glazing rebate area must be clean and free from grease, oil, dust, water, sealing compounds and release agents.

In order to clean the bonding surfaces, these must be pre-treated before the glass is installed (e.g. with OTTO Cleanprimer 1226). This applies to both the secondary edge seal and the rebate insert. The primer must be applied with a clean, lint-free cloth.

Do not wipe the primer off or apply the primer more than once.

The primer and adhesive must be compatible and be approved by the manufacturer or supplier.

The edge area of the glass must be checked for damage and dirt. Only undamaged glass may be processed.

If the bonding surface is dirty, e.g. with a secondary sealing compound, oil, dust, water or release agents, this must be removed without leaving any residues. The glass edge must then be primed. The manufacturer's instructions for the use of the primer must be observed.

Vorbehandlung beim Einsatz von Klebstoffen der Kömmerling GmbH:
Pre-treatment when using adhesives from Kömmerling GmbH:

Die Haftflächen im Glasfalzbereich müssen sauber und fettfrei sowie frei von Ölen, Staub, Wasser, Dichtstoffen oder Trennmitteln sein.

The bonding surfaces in the glazing rebate area must be clean and free from grease, oil, dust, water, sealing compounds and release agents.

Vor Beginn der Glasmontage ist folgendes zur Reinigung der Klebeflächen zu beachten. Den Glasrandverbund mit Ködiglaze Wash Cleaner und das PVC-Profil mit Ködiglaze PVC Primer (Ablüßzeit: mindestens 5 Minuten) behandeln.

Before the glass is installed, the following must be noted for the cleaning of the bonding surfaces. Treat the glass edge seal with Ködiglaze Wash Cleaner and the PVC profile with Ködiglaze PVC Primer (flash-off time: at least 5 minutes).

Den Isolierglasrandverbund mit Ködiglaze Wash Cleaner und einem fusselfreien Tuch oder Vlies feucht reinigen.

Clean the edge seal for the insulating glass with Ködiglaze Wash Cleaner and a damp, lint-free cloth or fleece.

Das PVC Profil muss vor dem Einbau des Glases mit Ködiglaze PVC Primer behandelt werden. Der Auftrag des Primers sollte möglichst dünn erfolgen.

The PVC profile must be treated with Ködiglaze PVC Primer before the glass is installed. The primer should be applied as thinly as possible.

Ködiglaze P härtet in Kombination mit Feuchtigkeit zu einem dauerelastischen Klebstoff aus, welcher von seinen mechanischen und chemischen Eigenschaften optimal auf Isolierglasdichtstoffe auf Basis PUR und PSR abgestimmt ist. Vor dem Einbringen des Klebstoffes wird der Falz leicht mit Wasser eingesprüht.

When combined with moisture, Ködiglaze P cures to make a permanently elastic adhesive, the mechanical and chemical properties of which make it perfectly adapted to sealing compounds for insulating glass based on PUR and PSR. Before introducing the adhesive, the rebate is sprayed lightly with water.

Die Verarbeitungsrichtlinien des Herstellers sind zu beachten!

The fabrication guidelines of the manufacturer must be taken into account.

Vorbehandlung der Klebeflächen Pre-treatment of the bonding surfaces		
	Otto-Chemie GmbH	Kömmerling GmbH
Glasrandverbund Glass edge seal	Cleanprimer 1226	Ködiglaze Wash Cleaner
Falzeinlage / Glasfalz Rebate insert / glazing rebate	Cleanprimer 1226	Profil mit Ködiglaze PVC Primer* Profile with Ködiglaze PVC Primer*

* Ablüßzeit beachten: mindestens fünf Minuten
* Observe the flash-off time: at least five minutes

Primer und Klebstoffe sind im Lieferumfang von Schüco nicht enthalten.

Primer and adhesives are not supplied by Schüco.

Primer

1. KÖDIGLAZE Wash Cleaner

Die Produktinformation und Sicherheitsdatenblätter können unter info@koe-chemie.de oder über den jeweiligen Händler angefordert werden.

Reinigungsprimer für die Reinigung des Isolierglasrandverbundes vor der Verklebung mit KÖDIGLAZE P.

2. KÖDIGLAZE PVC-Primer

Die Produktinformation und Sicherheitsdatenblätter können unter info@koe-chemie.de oder über den jeweiligen Händler angefordert werden.

Primer für die Vorbehandlung von PVC vor der Verklebung mit KÖDIGLAZE P.

3. OTTO Cleanprimer 1226

Das Technische Datenblatt und Sicherheitsdatenblätter sind unter www.otto-chemie.de verfügbar.

Klebstoffe

1. KÖDIGLAZE P

KÖDIGLAZE P ist ein Spezialklebstoff für die Falzgrundverklebung auf PUR Basis

Hersteller:
KÖMMERLING CHEMISCHE FABRIK GMBH
Zweibrücker Straße 200
D-66954 Pirmasens
E-Mail: info@koe-chemie.de
Web: www.koe-chemie.de

2. OTTOCOLL® S 81

OTTOCOLL® S 81 ist ein 2K-Silicon Klebstoff auf Alkoxy-Basis

Hersteller:
Hermann Otto GmbH
Krankenhausstraße 14
D-83413 Fridolfing
E-Mail: info@otto-chemie.de
Web: www.otto-chemie.de

Primer

1. KÖDIGLAZE Wash Cleaner

The product information and safety data sheets can be requested by emailing info@koe-chemie.de or from the respective distributor.

Cleaning primer for cleaning the edge seal of the insulating glass prior to bonding with KÖDIGLAZE P.

2. KÖDIGLAZE PVC-Primer

The product information and safety data sheets can be requested by emailing info@koe-chemie.de or from the respective distributor.

Primer for the pre-treatment of PVC prior to bonding with KÖDIGLAZE P.

3. OTTO Cleanprimer 1226

The technical data sheet and safety data sheets are available at www.otto-chemie.de.

Adhesives

1. KÖDIGLAZE P

KÖDIGLAZE P is a special adhesive based on polyurethane for bonding the rebate base

Manufacturer:
KÖMMERLING CHEMISCHE FABRIK GMBH
Zweibrücker Straße 200
D-66954 Pirmasens
E-Mail: info@koe-chemie.de
Web: www.koe-chemie.de

2. OTTOCOLL® S 81

OTTOCOLL® S 81 is a 2-component, alkoxy-based silicon adhesive

Manufacturer:
Hermann Otto GmbH
Krankenhausstraße 14
D-83413 Fridolfing
E-Mail: info@otto-chemie.de
Web: www.otto-chemie.de

Verträglichkeitsprüfungen

1. KÖDIGLAZE P

Die Produktinformation und Sicherheitsdatenblätter können unter info@koe-chemie.de oder über den jeweiligen Händler angefordert werden.

Die Verträglichkeit ist mit folgenden Isolierglasdichtstoffen von Kömmerling gewährleistet:

GD 116
GD 116 NA
GD 677
Naftotherm M 82

Die Verträglichkeit mit den meisten Isolierglasdichtstoffen anderer Hersteller wurde geprüft. Eine Freigabe kann auf Anfrage erteilt werden.

2. OTTOCOLL® S 81

Das Technische Datenblatt und Sicherheitsdatenblätter sind unter www.otto-chemie.de verfügbar.

Eine generelle Bestätigung der Verträglichkeit zwischen Klebstoff und Glasrandverbund kann erteilt werden, wenn eine vertragliche Vereinbarung existiert über die gegenseitige Informationspflicht bei Spezifikations-, Rezeptur- und Verfahrensänderungen.

Grundsätzlich ist vor Verklebung die Verträglichkeit des Klebstoffes mit dem Glasrandverbund einzuholen!

Compatibility tests

1. KÖDIGLAZE P

The product information and safety data sheets can be requested by emailing info@koe-chemie.de or from the respective distributor.

Compatibility is assured with the following sealing compounds for insulating glass from Kömmerling:

GD 116
GD 116 NA
GD 677
Naftotherm M 82

Compatibility with most sealing compounds has been verified for insulating glass from other manufacturers. An approval can be issued on request.

2. OTTOCOLL® S 81

The technical data sheet and safety data sheets are available at www.otto-chemie.de.

A general confirmation of compatibility between the adhesive and glass edge seal can be issued if a contractual agreement exists regarding the obligation to provide the other party with information in the event of changes to the specifications, compositions and procedures.

The compatibility of the adhesive with the glass edge seal must be ascertained prior to bonding.

Dämmfalzeinleger

Insulating rebate inserts

Eigenschaften:

- Verbesserung des U_f -Wertes
- Wärmeleitfähigkeit von 0,04 W/mk
- Optimiert für einen Glaseinstand von 20 mm
- Polyethylenschaum (PEX)
- UV-beständig
- Temperatur- und feuchtebeständig
- 100% recyclebar
- Einsetzbar für LivIng 82 AS und MD

Properties:

- Improvement of U_f value
- Thermal conductivity of 0.04 W/mK
- Optimised for a glass edge cover of 20 mm
- Polyethylene foam (PEX)
- UV-resistant
- Temperature and moisture-resistant
- 100% recyclable
- Can be used for LivIng 82 AS and MD

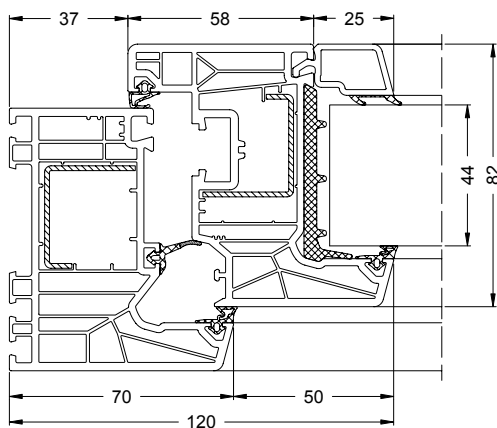

Schnitt Schüco LivIng 82 MD mit Dämmfalzeinleger 67 LivIng
Section detail for Schüco LivIng 82 MD with LivIng insulating rebate insert 67

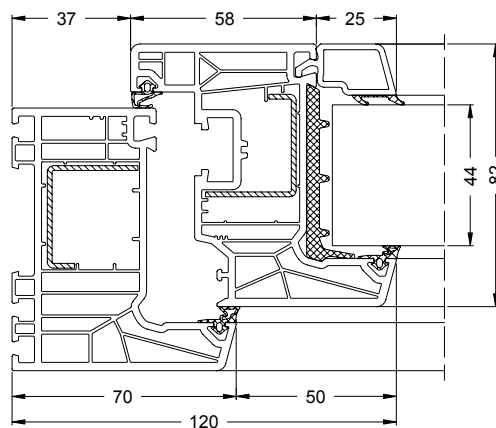

Schnitt Schüco LivIng 82 AS mit Dämmfalzeinleger 67 LivIng
Section detail for Schüco LivIng 82 AS with LivIng insulating rebate insert 67

Dämmfalzeinleger 67 LivIng ■ LivIng insulating rebate insert 67 25264700



Ziersprossen

Decorative sash bars

Ziersprosse 9/27
Decorative sash bar 9/27

19223...



Ziersprosse 11/27
Decorative sash bar 11/27

19181...



Ziersprosse 13/27
Decorative sash bar 13/27

19182...



Ziersprosse 13/34
Decorative sash bar 13/34

19183...



Alu-Ziersprosse 12/25
Aluminium decorative sash bar 12/25

13296000 roh ■ Mill finish

13296010 weiß ■ White braun ■ Brown

17101... foliert ■ Foiled



Alu-Ziersprosse 12/36
Aluminium decorative sash bar 12/36

13296100 roh ■ Mill finish

13296110 weiß ■ White braun ■ Brown

17103... foliert ■ Foiled



Ziersprosse 13/45
Decorative sash bar 13/45

19184...

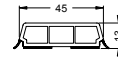

Ziersprosse 13/65
Decorative sash bar 13/65

19185...

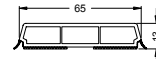

Design-Ziersprosse 13/34
Feature decorative sash bar 13/34

19186...



Alu-Ziersprosse 12/45
Aluminium decorative sash bar 12/45

13297700 roh ■ Mill finish

13297710 weiß ■ White braun ■ Brown

17116... foliert ■ Foiled

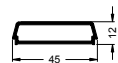

Hinweis:

Es ist zu beachten, dass die Tiefe der Glasleiste größer als die Höhe der Ziersprosse sein muss.

Note:

Ensure that the depth of glazing bead is greater than the height of the decorative sash bar.

Hinweise Design-Ziersprosse Notes on feature decorative sash bar

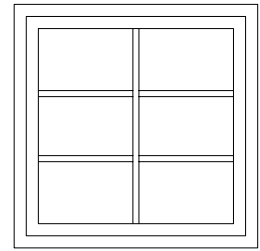
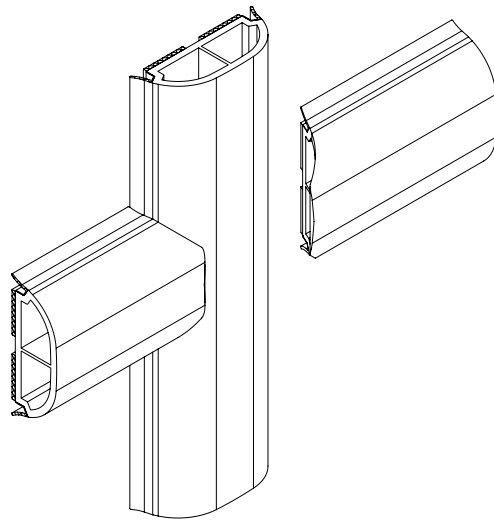

Fräsung der Design-Ziersprosse
Machining of the feature decorative sash bar

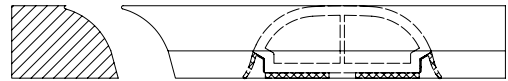

Auslinkfräsen Fräsersätze

Milling tool sets for end milling machines

Art.-Nr. Art. No.	Benennung Description		i	
28635000	Fräsersatz Milling tool set	1 Stk.	Graule AKF 6	Fräswelle Ø 40/ linksdrehend/ Ø-Außen 200 Milling shaft Ø 40 / turning to the left / Ø outside 200
28635100	Fräsersatz Milling tool set	1 Stk.	Rotox SAF 165/ 166/ 167	Fräswelle Ø 40/ rechtsdrehend/ Ø-Außen 140 Milling shaft Ø 40 / turning to the right / Ø outside 140

Gestaltungsmöglichkeiten Design options

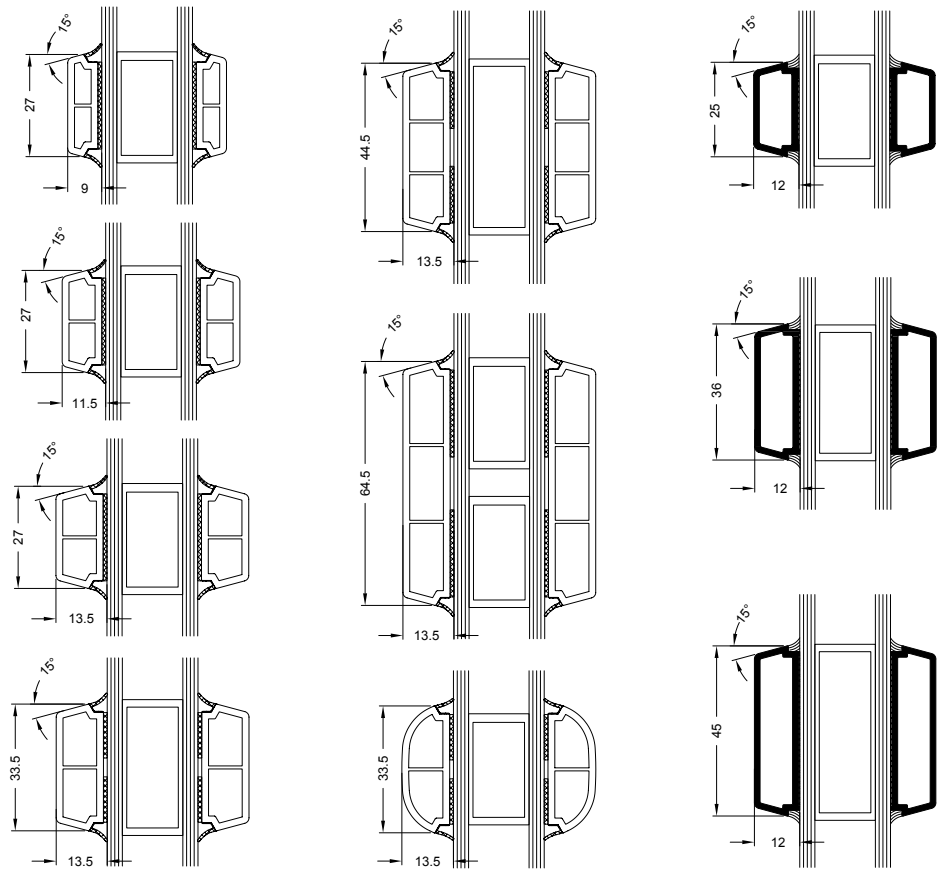

Maßstab 1:2
Scale 1:2

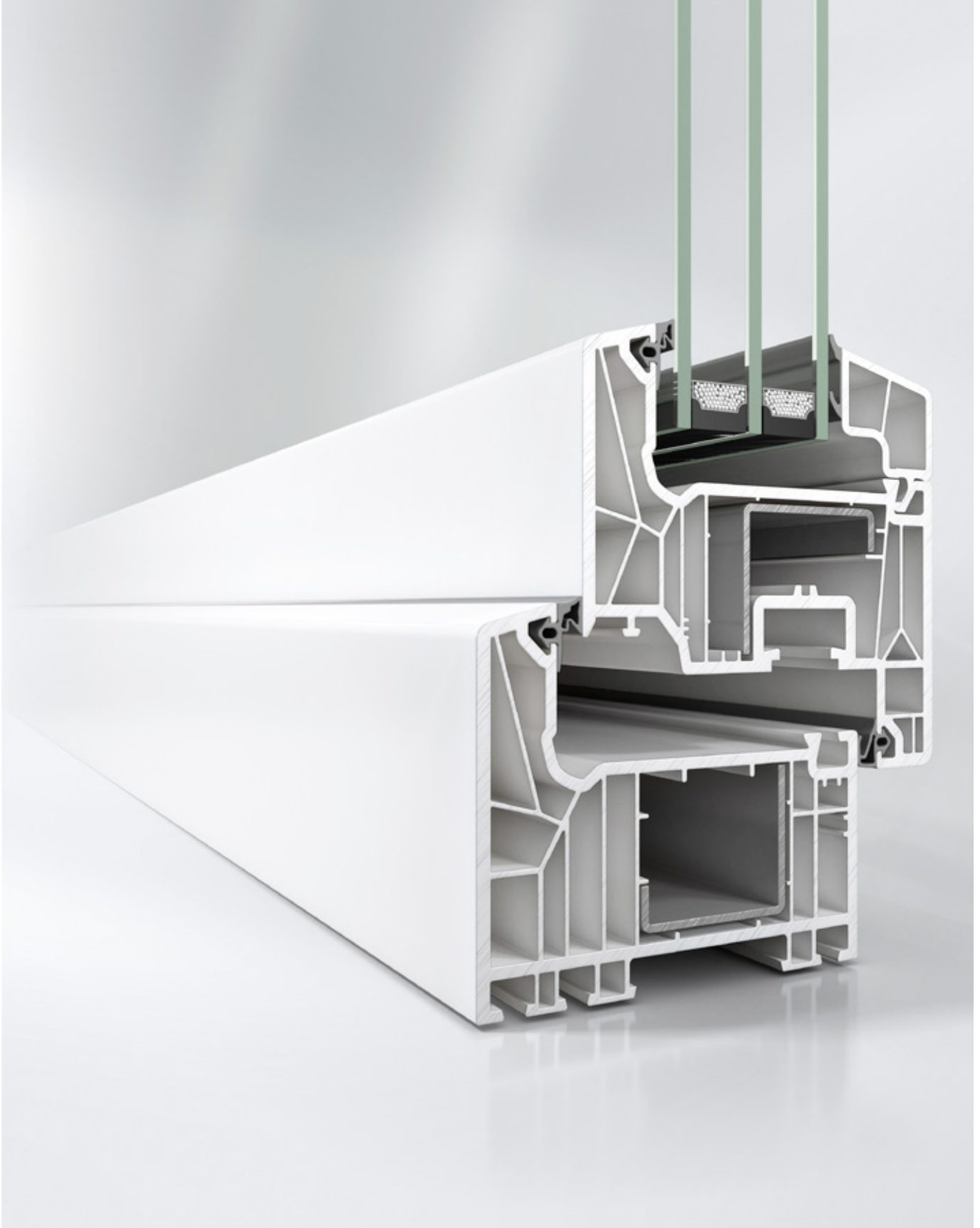

Schnittdarstellungen 1:1
Section details 1:1

- 114 Festverglasungen
Fixed glazing
- 118 Fensterschnitte
Window section details
- 128 Schnitte Nebeneingangstür
Section details for side entrance door
- 129 Schnitte Haustür
Section details for front door
- 131 Schnitte flügelüberdeckende Türfüllung
Section details for leaf-enclosing door infill

Festverglasungen

Fixed glazing

Festverglasung Blendrahmen mit Anschlagdichtung

Fixed glazing in outer frame with rebate gasket

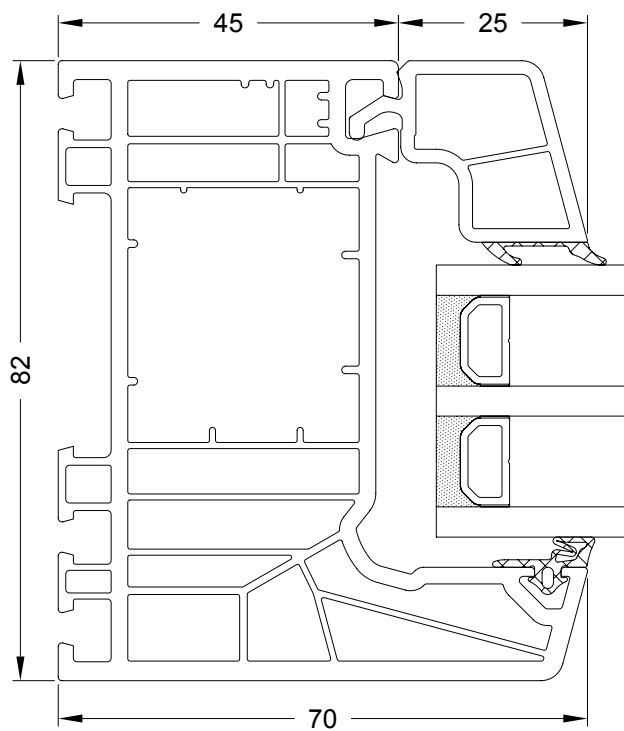

Schnittdarstellungen 1:1
Section details 1:1



19421...

Festverglasung Blendrahmen mit Mitteldichtung
Fixed glazing in outer frame with centre gasket

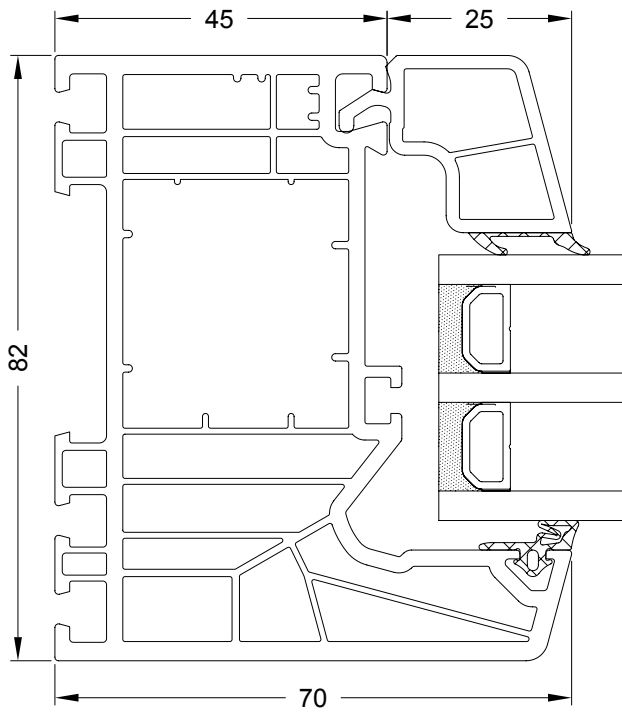

19411...

Festverglasung T-Profil mit Anschlagdichtung
Fixed glazing in T-profile with rebate gasket

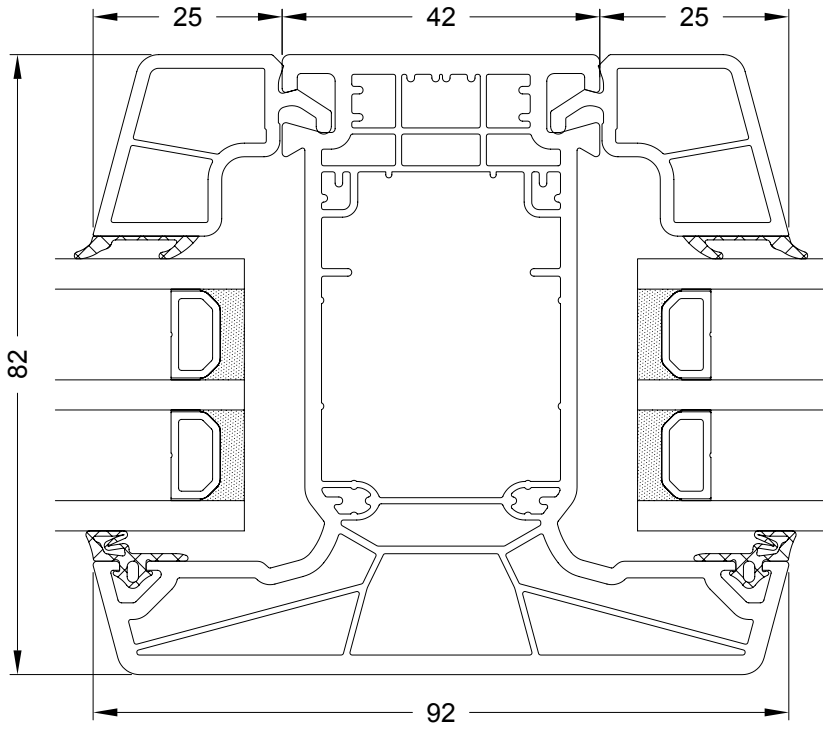

Schnittdarstellungen 1:1
Section details 1:1



19461...

Festverglasung T-Profil mit Mitteldichtung
Fixed glazing in T-profile with centre gasket

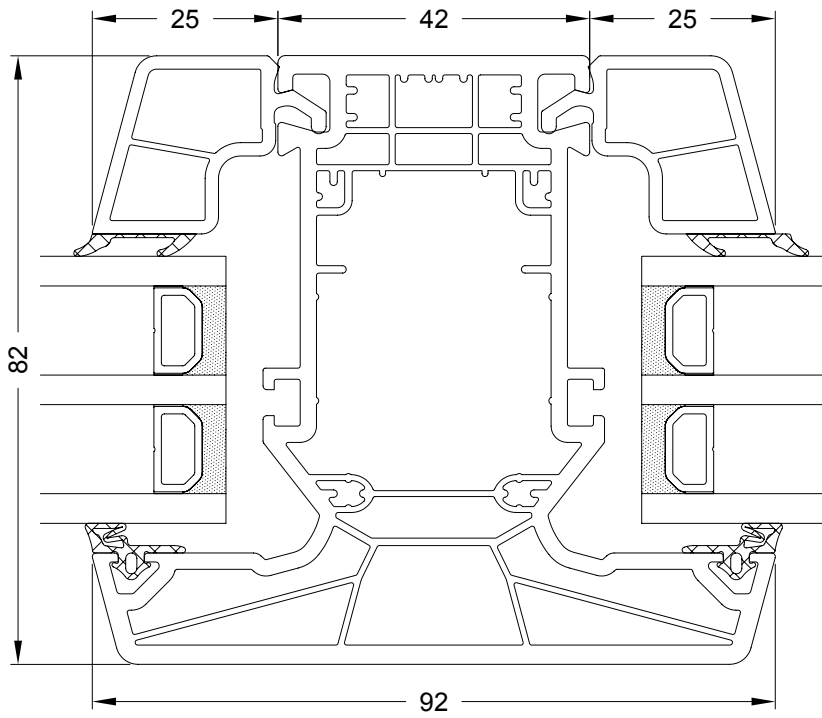

19465...

Fensterschnitte

Window section details

Kombination Blendrahmen mit Anschlagdichtung und Flügelrahmen
Combination of outer frame with rebate gasket and vent frame

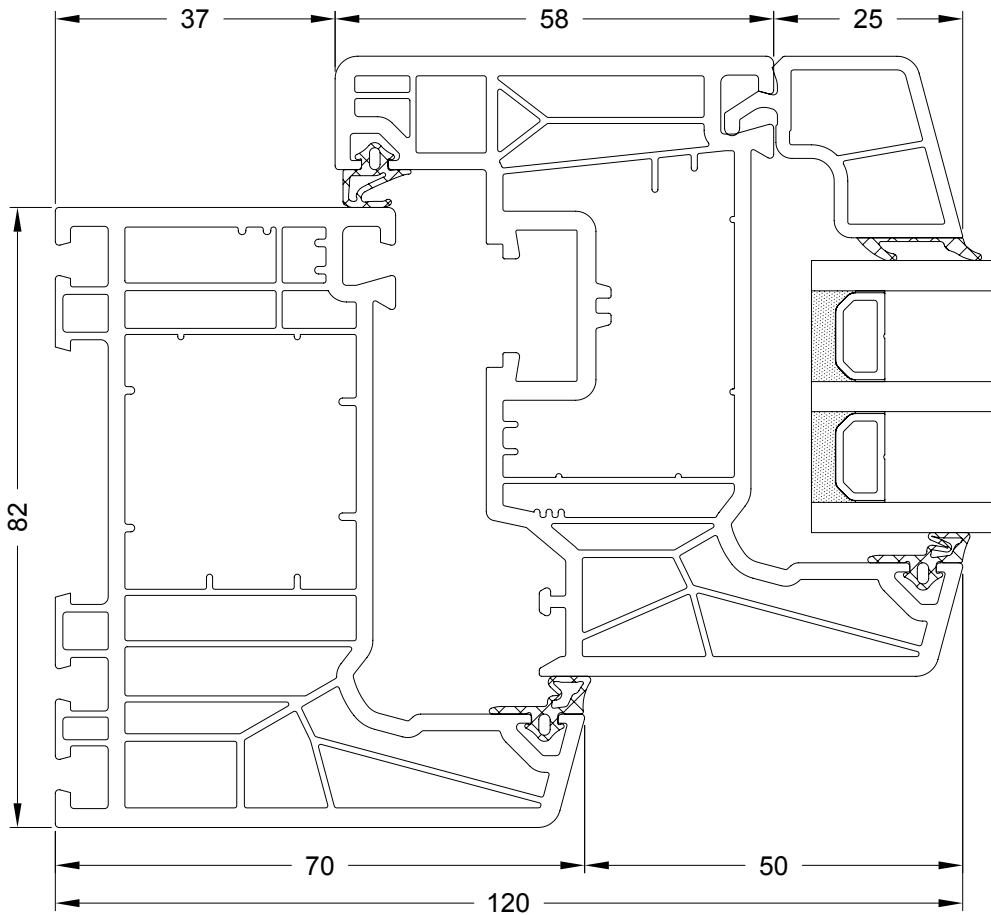

Schnittdarstellungen 1:1
Section details 1:1

 19421...

 19431...

Kombination Blendrahmen mit Mitteldichtung und Flügelrahmen
Combination of outer frame with centre gasket and vent frame

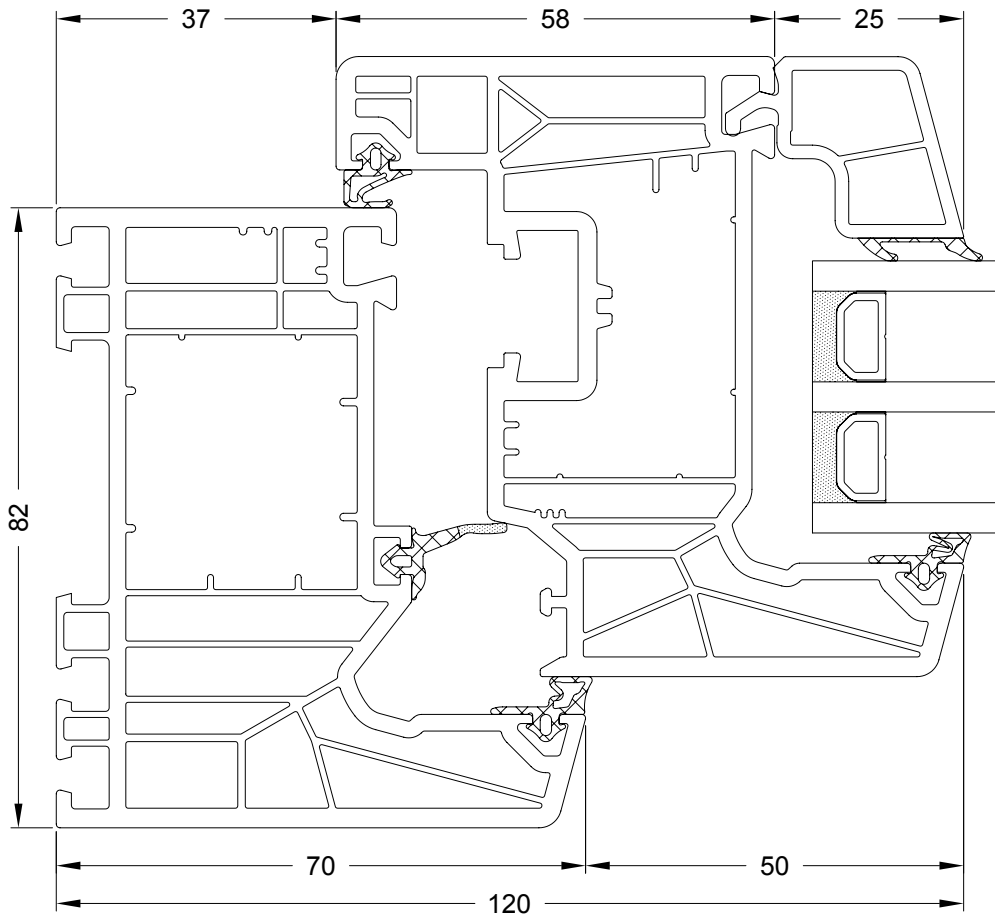

 19411...

 19431...

Kombination T-Profil mit Anschlagdichtung und Flügelrahmen
Combination of T-profile with rebate gasket and vent frame

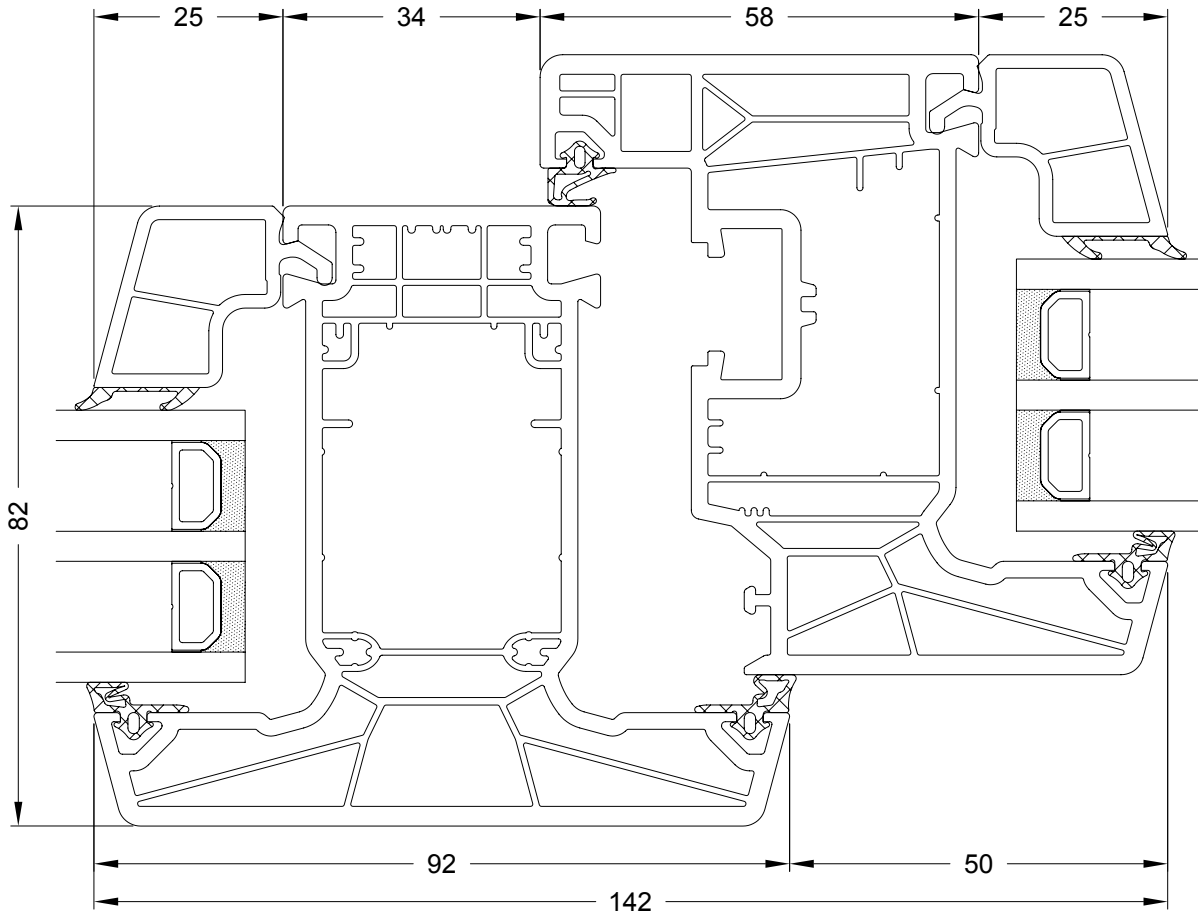

Schnittdarstellungen 1:1
Section details 1:1

 19461...

 19431...

Kombination T-Profil mit Mitteldichtung und Flügelrahmen
Combination of T-profile with centre gasket and vent frame

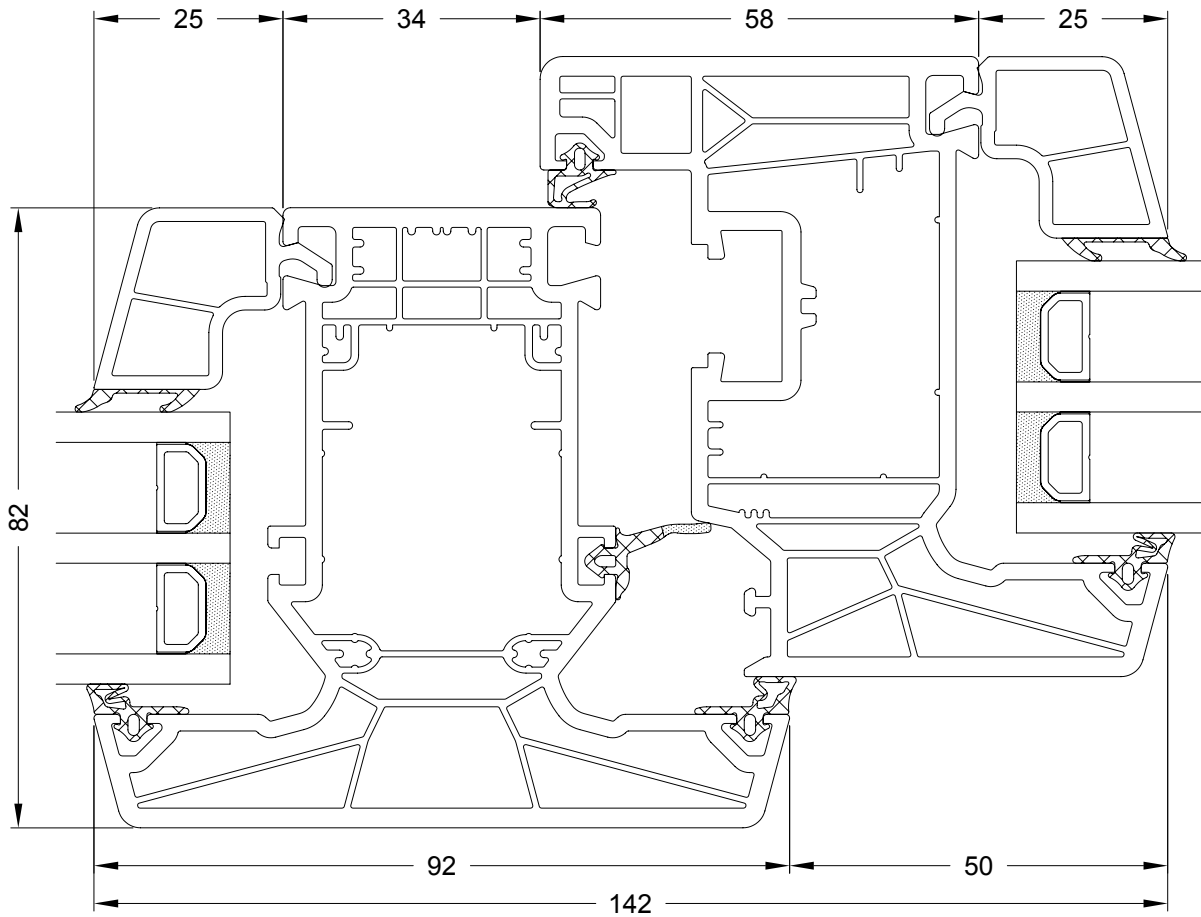

19465...



19431...

Kombination Stulpprofil mit Mitteldichtung und Flügelrahmen
Combination of double-vent profile with centre gasket and vent frame

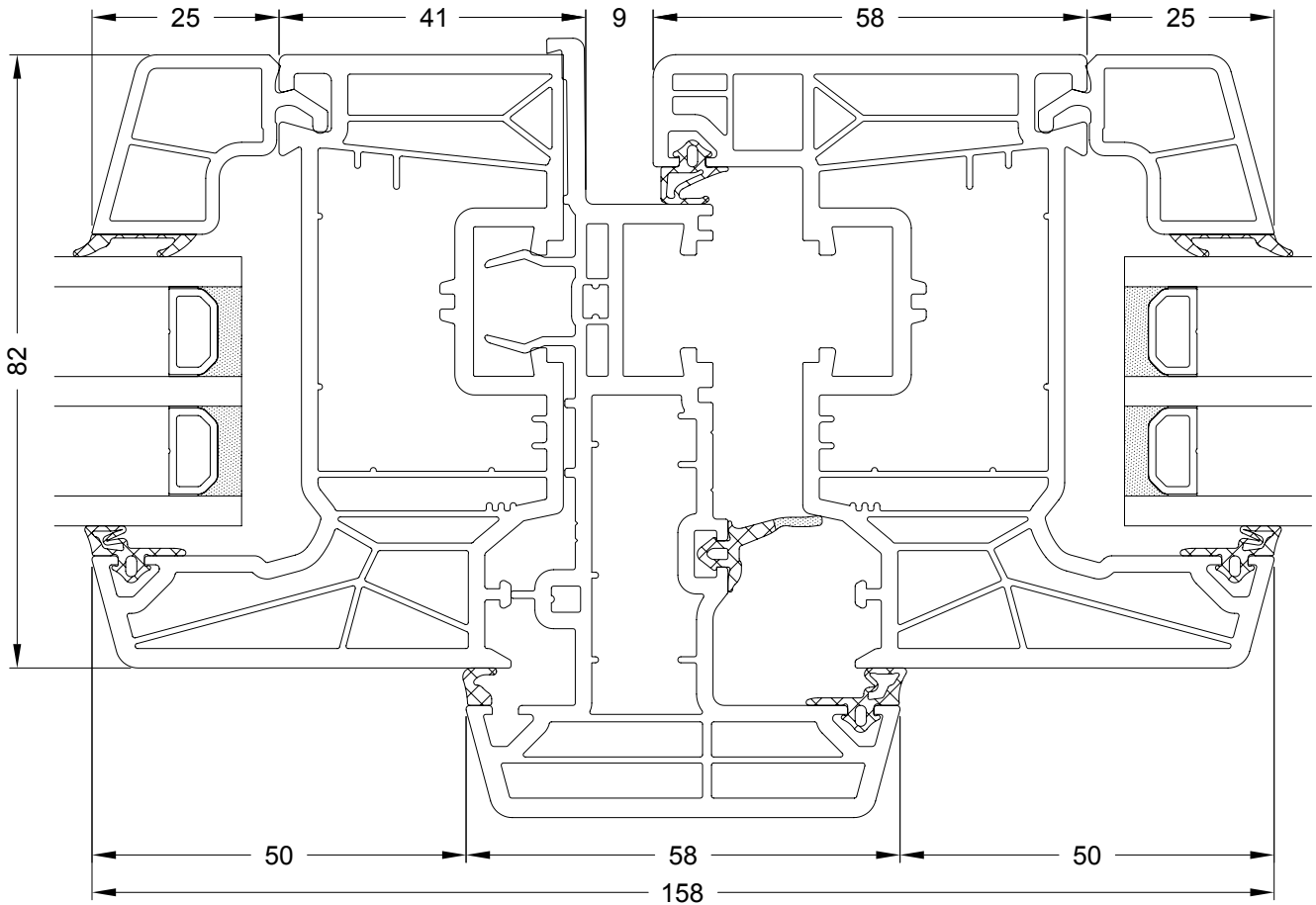



Schnittdarstellungen 1:1
Section details 1:1

 19431...

 19471...

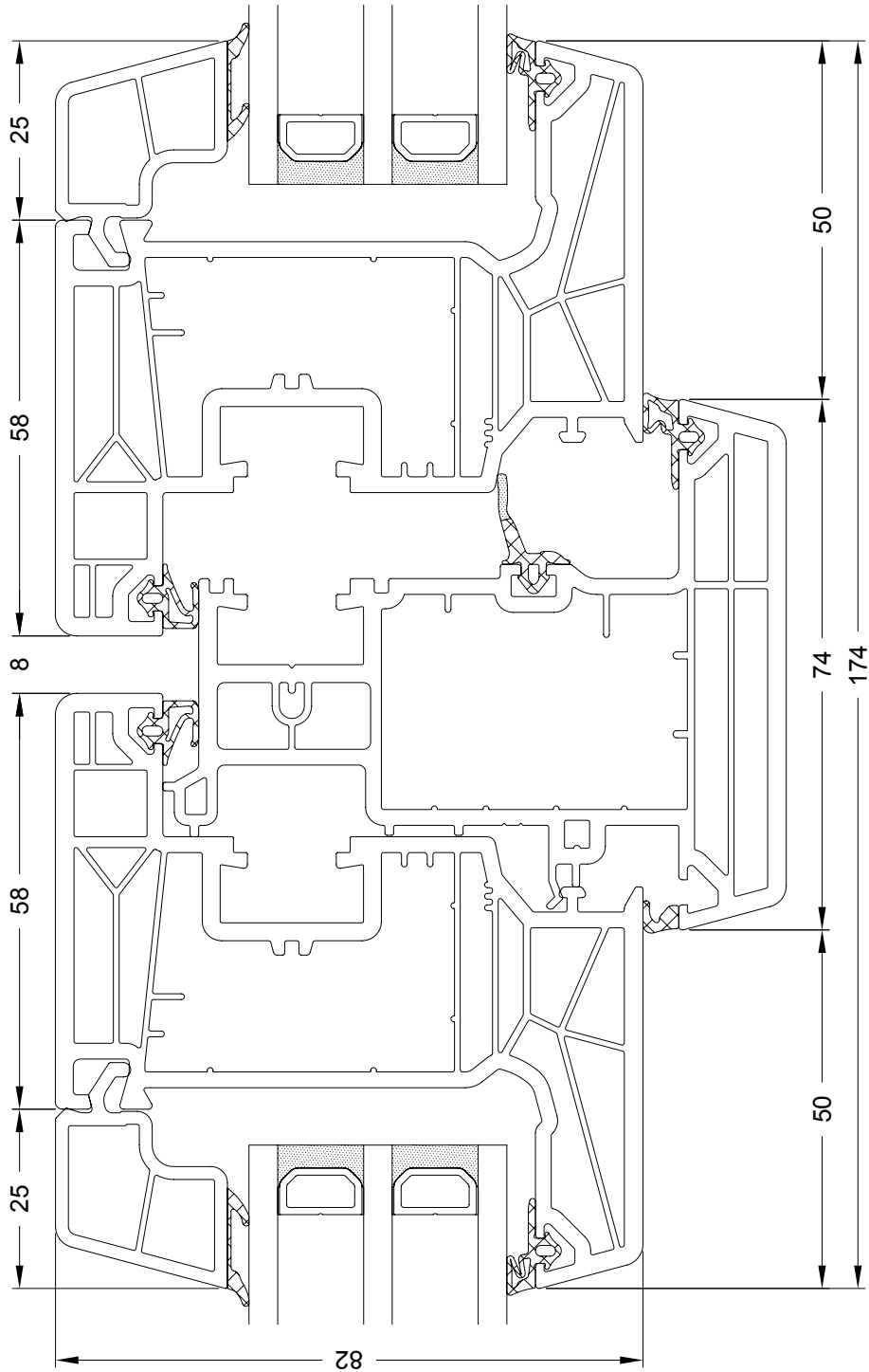
Kombination Stulpprofil mit Mitteldichtung und Flügelrahmen
Combination of double-vent profile with centre gasket and vent frame



19431...

19472...

Kombination Blendrahmen mit Anschlagdichtung und Klebeflügel
Combination of outer frame with rebate gasket and adhesive vent

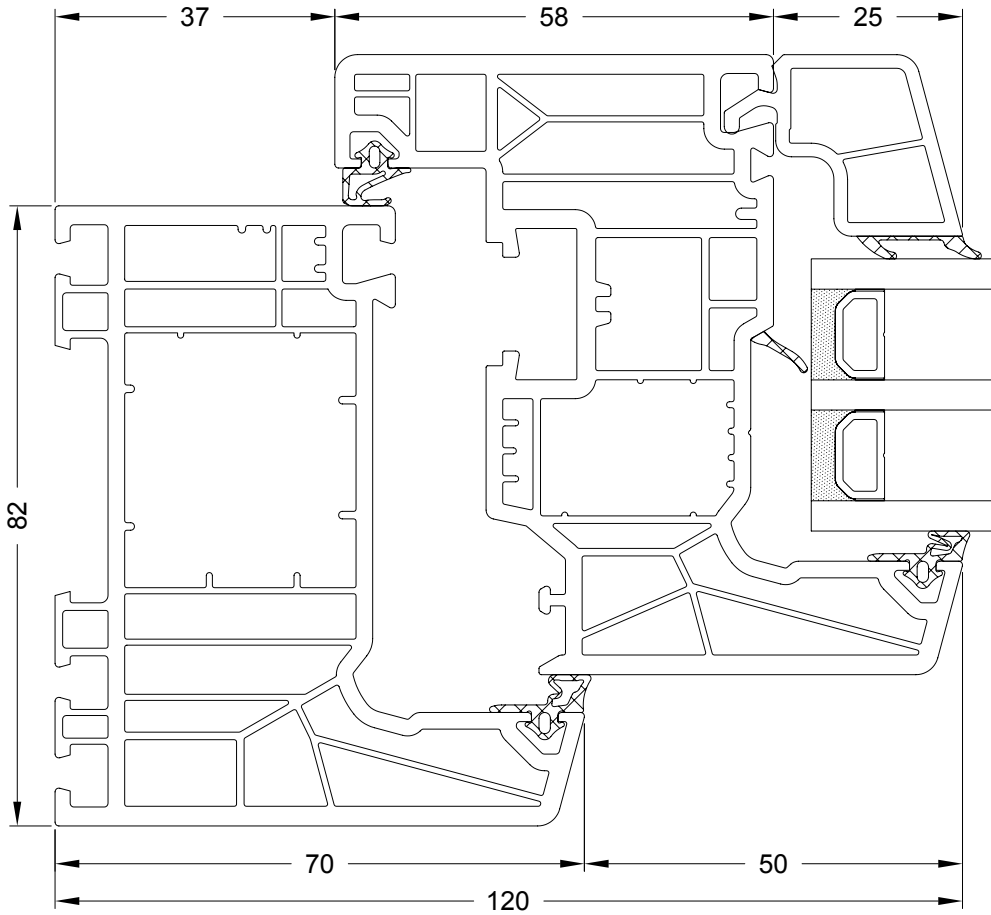

Schnittdarstellungen 1:1
Section details 1:1

 19421...

 19434...

Kombination Blendrahmen mit Mitteldichtung und Klebeflügel
Combination of outer frame with centre gasket and adhesive vent

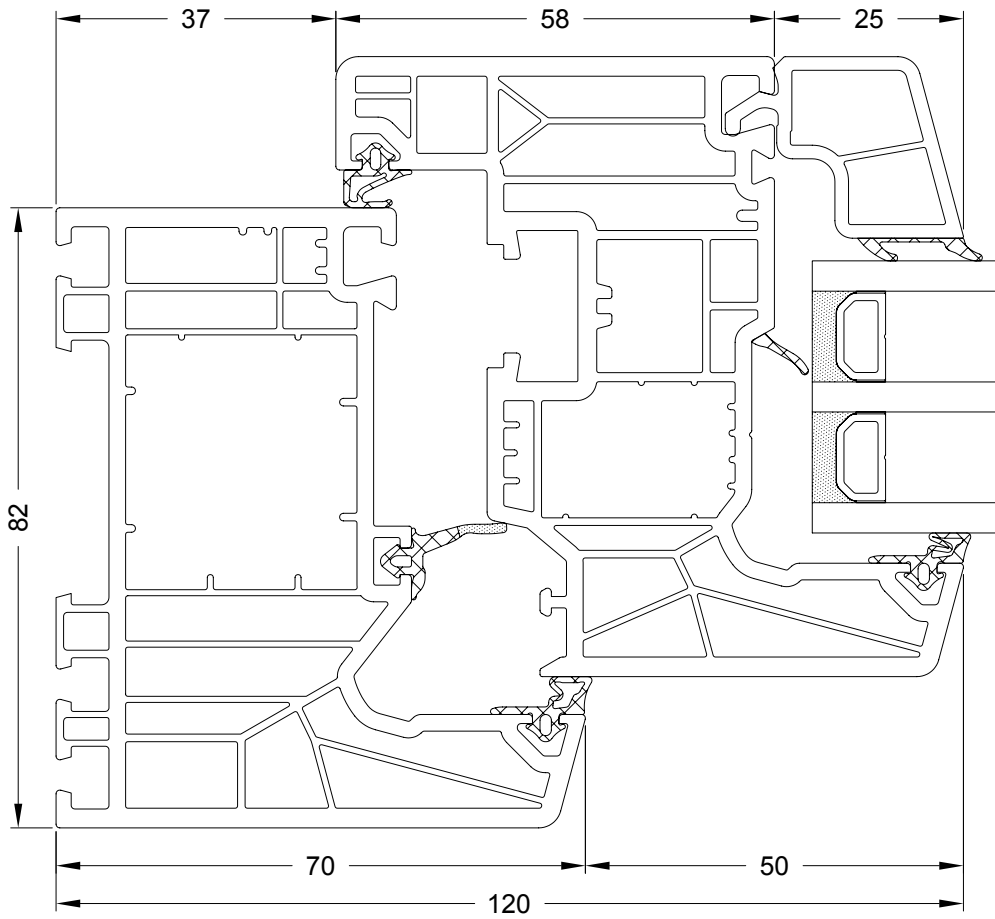

 19411...

 19434...

Kombination T-Profil mit Anschlagdichtung und Klebeflügel
Combination of T-profile with rebate gasket and adhesive vent

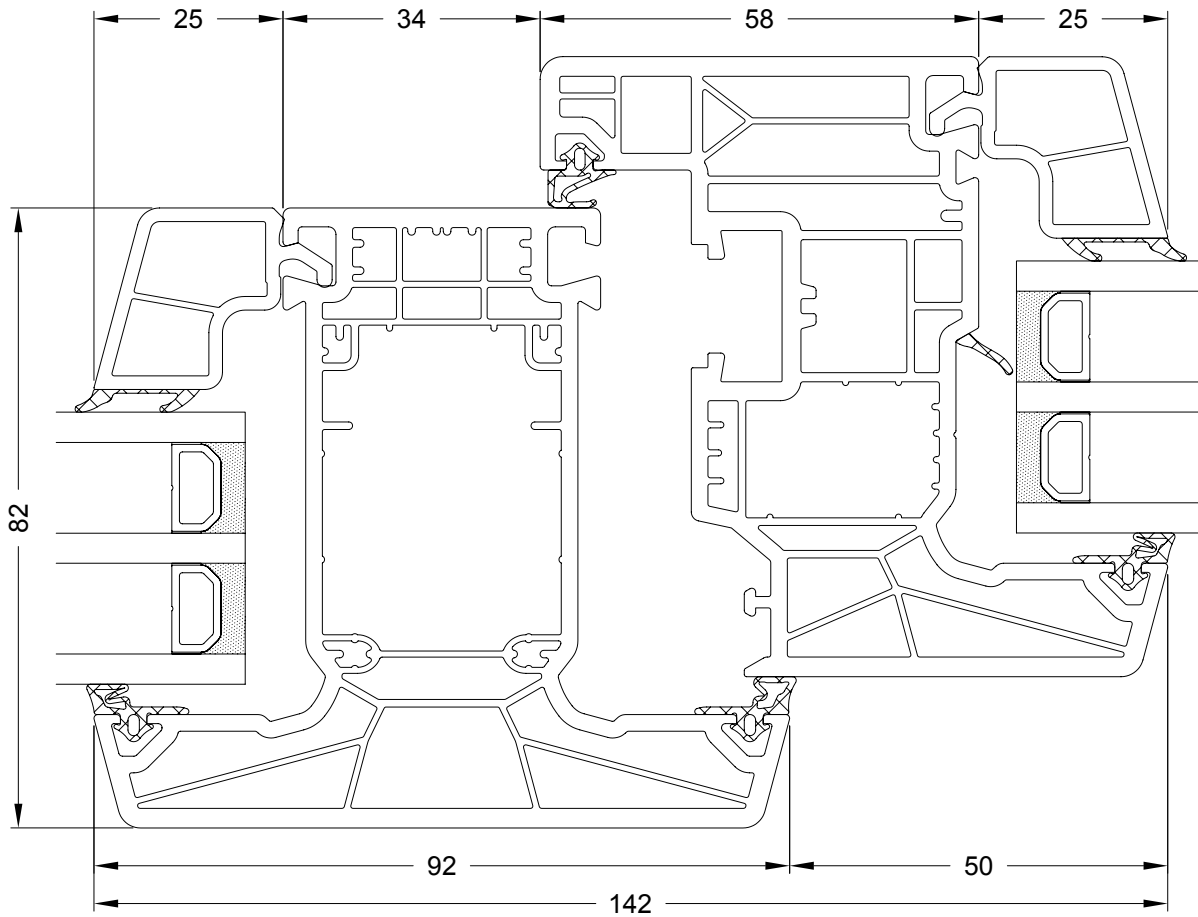

Schnittdarstellungen 1:1
Section details 1:1

 19461...

 19434...

Kombination T-Profil mit Mitteldichtung und Klebeflügel
Combination of T-profile with centre gasket and adhesive vent

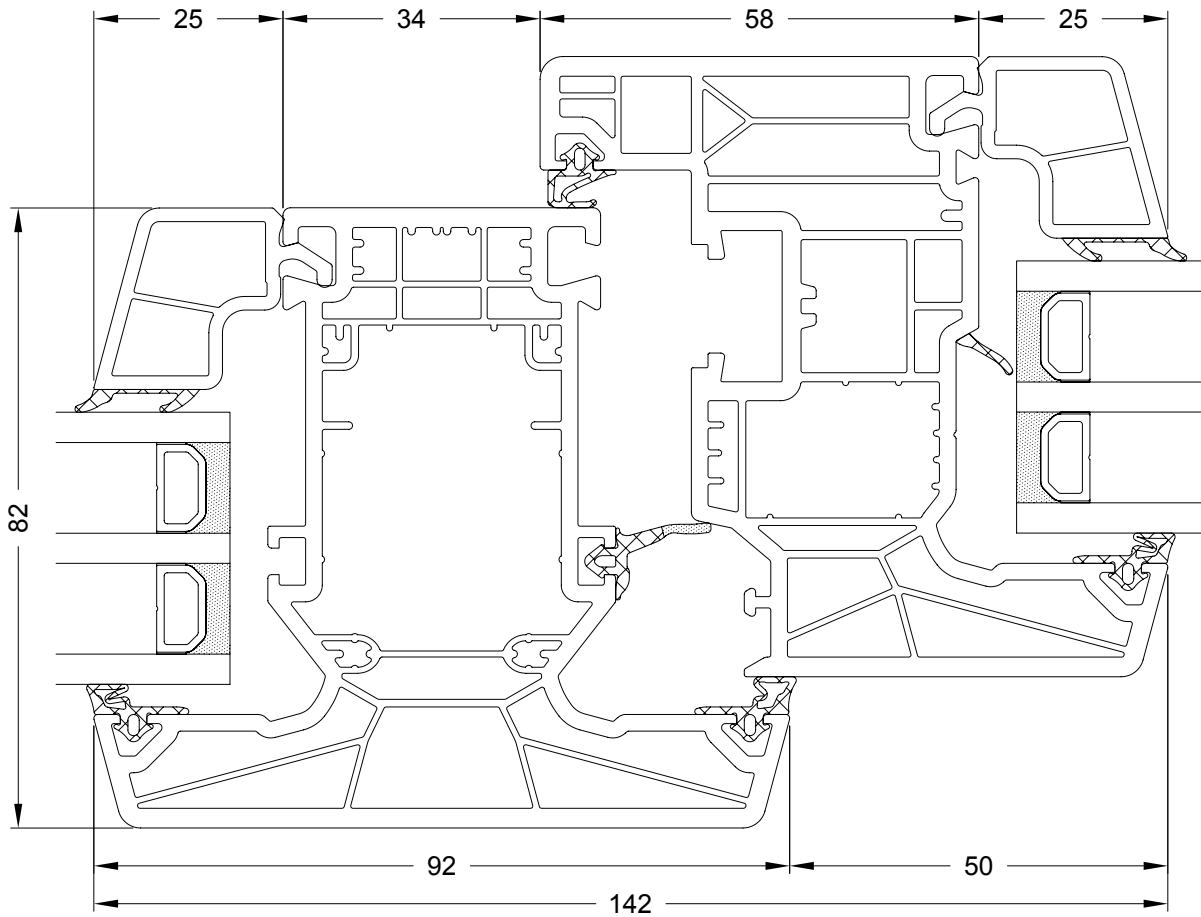

19465...



19434...

Schnitte Nebeneingangstür

Section details for side entrance door

Kombination Flügelrahmen und Stulpprofil für Nebeneingangstür
Combination of leaf frame and meeting stile profile for side entrance door

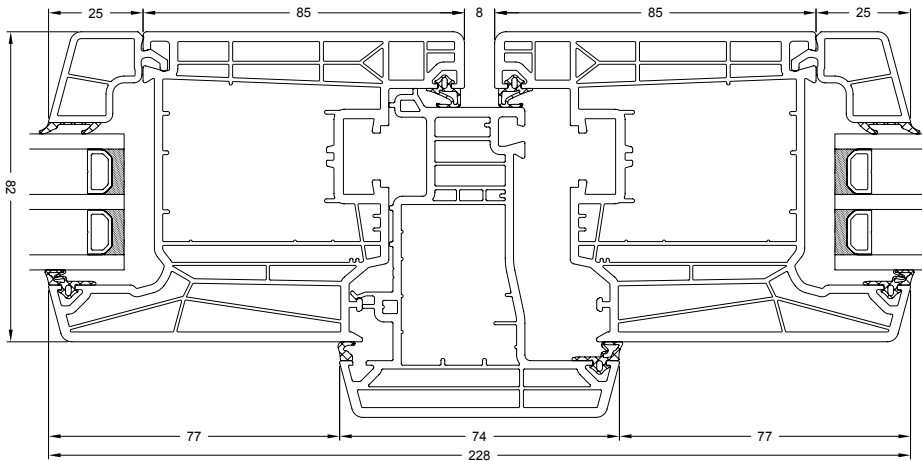

Maßstab 1:2
Scale 1:2

 **19432...**

 **19473...**

Kombination Flügelrahmen und Stulpprofil für Nebeneingangstür nach außen öffnend
Combination of leaf frame and meeting stile profile for side entrance door, outward-opening

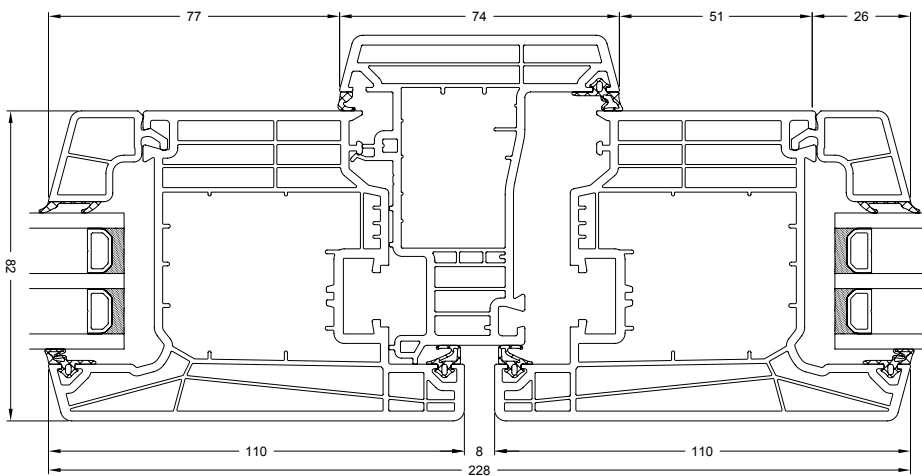

Maßstab 1:2
Scale 1:2

 **19452...**

 **19473...**

Schnitte Haustür

Section details for front door

Kombination Flügelrahmen und Stulpprofil für Haustür
Combination of leaf frame and meeting stile profile for entrance door

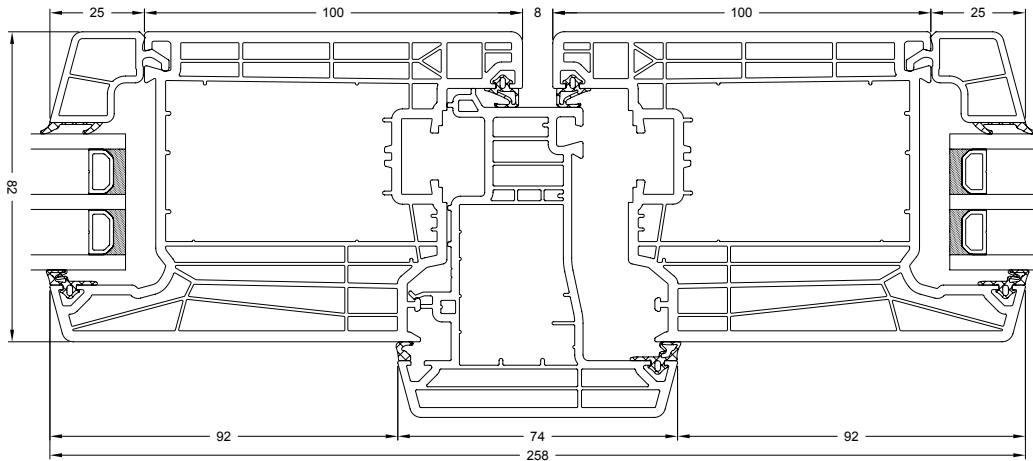

Maßstab 1:2
Scale 1:2



19433...



19473...

Kombination Flügelrahmen und Stulpprofil für Haustür nach außen öffnend
Combination of leaf frame and meeting stile profile for entrance door, outward-opening

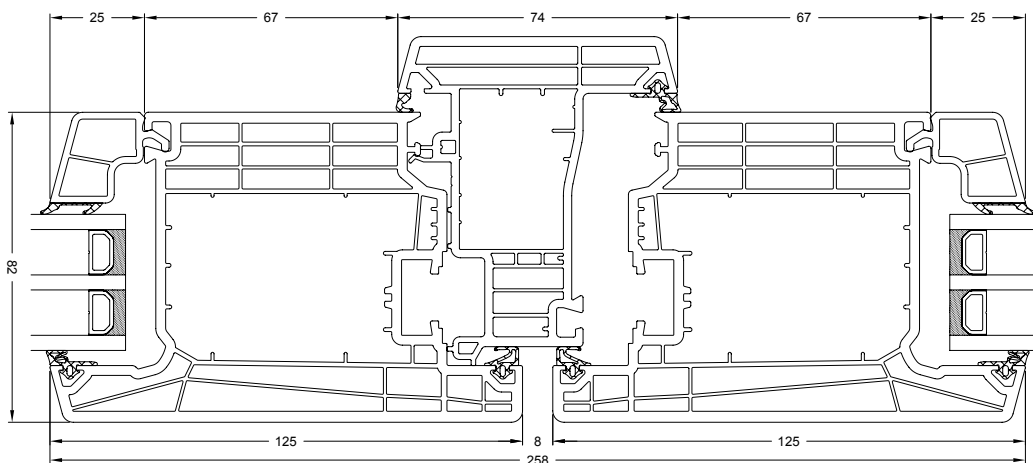

Maßstab 1:2
Scale 1:2



19453...



19473...

Schnitte flügelüberdeckende Türfüllung

Section details for leaf-enclosing door infill

Kombination Blendrahmen und Flügelrahmen für flügelüberdeckende Türfüllung
Combination of outer frame and leaf frame for leaf-enclosing door infill

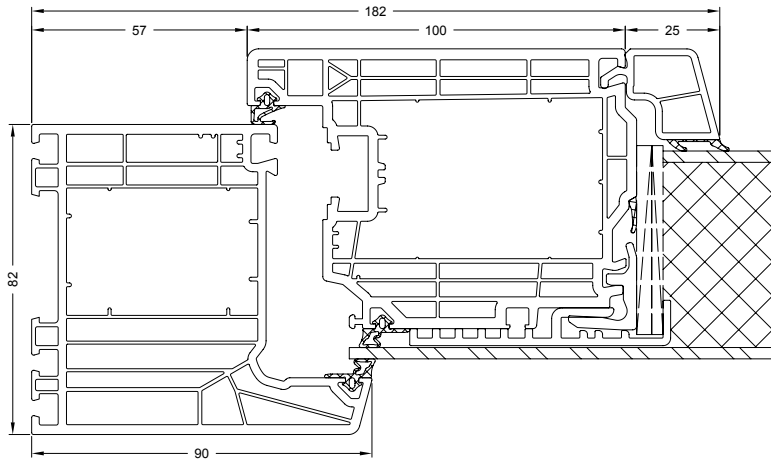

Maßstab 1:2
Scale 1:2

 **19423...**

 **19435...**

Kombination T-Profil und Flügelrahmen für flügelüberdeckende Türfüllungen
Combination of T-profile and leaf frame for leaf-enclosing door infills

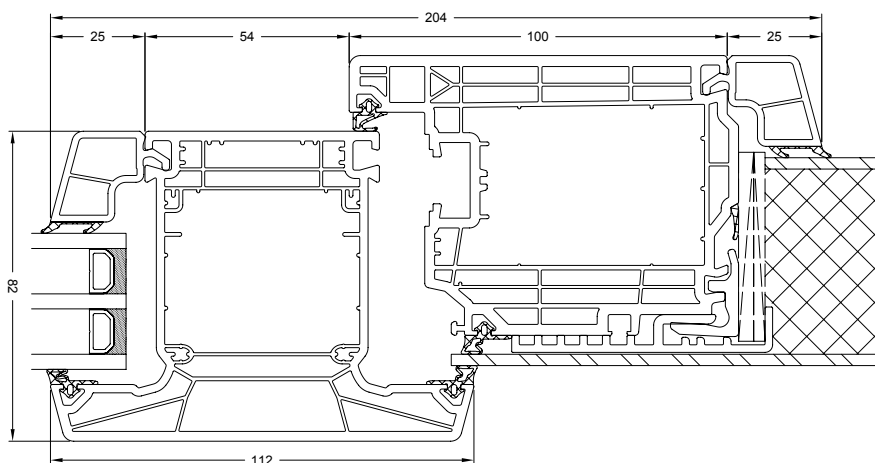

Maßstab 1:2
Scale 1:2

 **19462...**

 **19435...**

Kombination Stulpprofil und Flügelrahmen für flügelüberdeckende Türfüllungen
Combination of meeting stile profile and leaf frame for leaf-enclosing door infills

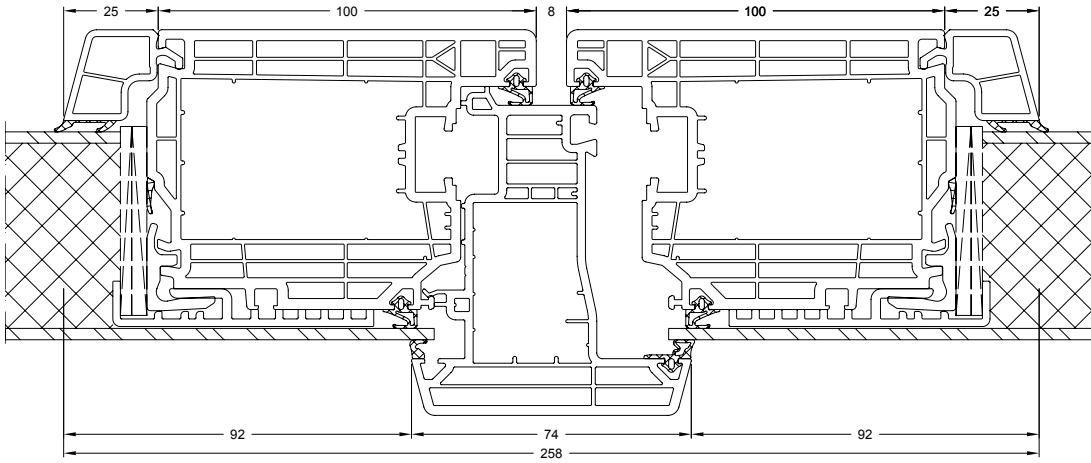

 19435...

 19473...